

**Performance Demonstration Program Plan for  
Nondestructive Assay of Boxed Wastes for  
the TRU Waste Characterization Program**

**Revision 1  
April 2008**



**This document supersedes Revision 0 of  
DOE/CBFO-01-1006**

**U.S. Department of Energy  
Carlsbad Field Office  
Office of the National TRU Program**

**This document has been submitted as required to:**

**Office of Scientific and Technical Information  
PO Box 62  
Oak Ridge, TN 37831  
(865) 576-1188**

**Additional information about this document may be obtained by calling the WIPP Information Center at 1-800-336-9477. Copies may be obtained by contacting the National Technical Information Service, U.S. Department of Commerce, 5285 Port Royal Road, Springfield, VA 22101.**

**Performance Demonstration Program Plan  
for Nondestructive Assay of Boxed Wastes for  
the TRU Waste Characterization Program**

**DOE/CBFO-01-1006**

**Revision 1**

**April 2008**

Approved By: //Signature on file// Date: \_\_\_\_\_  
Office Director  
Office of the National TRU Program

Concurred By: //Signature on file// Date: \_\_\_\_\_  
Quality Assurance Manager

Prepared By: //Signature on file// Date: \_\_\_\_\_  
PDP Appointee  
Office of the National TRU Program

## TABLE OF CONTENTS

ACRONYMS AND ABBREVIATIONS .....	6
1.0 INTRODUCTION.....	8
1.1 General .....	8
1.2 Purpose .....	9
1.3 Scope and Frequency .....	9
1.4 Radioisotopes, Activities, and Waste Matrices .....	11
2.0 PROGRAM COORDINATION .....	12
2.1 General Responsibilities.....	12
2.1.1 Facility Measurement Organization Contacts and General Responsibilities.....	14
2.2 Program Assessment .....	14
2.3 Procurement .....	15
2.4 Training.....	15
3.0 PREPARATION AND DISTRIBUTION OF RADIOACTIVE STANDARDS AND SWB MATRIX BOXES .....	16
3.1 Overview .....	16
3.2 PDP Radioactive Material Standards .....	16
3.3 PDP Surrogate Waste Matrices and Boxes .....	17
3.4 PDP Sample Component Control and Use.....	18
3.4.1 PDP Sample Components Receipt .....	18
3.4.2 PDP Sample Components Configuration Control and Repair .....	19
4.0 TEST SAMPLE PREPARATION .....	19
4.1 Responsibilities .....	19
4.2 NDA PDP Sample Preparation Instructions.....	20
5.0 ANALYTICAL AND DATA REPORTING REQUIREMENTS .....	23
5.1 NDA PDP Sample Receipt and Custody.....	23
5.2 Analysis.....	23
5.3 Reporting.....	24
5.3.1 Report Contents .....	24
5.3.2 Analytical Records .....	25
5.4 Completion and Disassembly.....	25

6.0 EVALUATION OF PERFORMANCE DATA .....27

    6.1 Scoring the Test Data Precision .....28

    6.2 Scoring the Test Data Bias .....28

    6.3 Use of NDA PDP Test Performance to Support WIPP Qualification.....30

7.0 REPORTING PERFORMANCE DATA.....32

    7.1 Summary of Data .....32

    7.2 Distribution of Reports.....32

    7.3 Supplemental NDA PDP Cycles .....34

    7.4 Facility Measurement Organization Status .....33

8.0 QA RECORDS FOR THE NDA PDP .....34

9.0 GLOSSARY .....37

10.0 REFERENCES .....40

Appendix A NDA Box PDP Registration Form.....42

Appendix B NDA PDP Standard Encapsulation Design .....48

Appendix C SWB Matrix Box Specifications and Descriptions.....51

Appendix D NDA Performance Demonstration Program Form .....59

Appendix E Statistical Basis of NDA PDP Scoring Criteria .....65

## ACRONYMS AND ABBREVIATIONS

%R	percent recovery
%RSD	percent relative standard deviation
CBFO	Carlsbad Field Office
DOE	U.S. Department of Energy
FGE	fissile gram equivalent
MDC	minimum detectable concentration
NDA	nondestructive assay
NTP	Office of the National TRU Program
PDP	Performance Demonstration Program
QA	quality assurance
QAO	quality assurance objective
QAPD	<i>Quality Assurance Program Document</i>
SNM	special nuclear material
SOP	standard operating procedure
SPT	sample preparation team
SWB	standard waste box
TID	tamper indicating device
TRU	transuranic
TWBIR	Transuranic Waste Baseline Inventory Report
WAC	Waste Acceptance Criteria
WGPu	weapons grade plutonium
WIPP	Waste Isolation Pilot Plant

## **Significant Changes to the Box Waste NDA PDP Plan, Revision 1**

### **General**

This document supersedes Revision 0 of the *Performance Demonstration Program Plan for Nondestructive Assay of Boxed Wastes for the TRU Waste Characterization Program* (DOE/CBFO-01-1006), and is a complete rewrite of that document. This revision constitutes a complete revision of each page; therefore, no change bars are included.

The document was rewritten to:

1. Better represent current practices and documents utilized by the Carlsbad Field Office (CBFO)
2. Eliminate concept and protocol for identical systems
3. Simplify and clarify the scoring section (section 6)
4. Clarify the explanation of the derivation of scoring criteria – Appendix E
5. Update the NDA Box PDP Plan to be consistent with the current revision of the NDA Drum PDP Plan
6. Incorporate changes in the CBFO organizational chart

## 1.0 INTRODUCTION

### 1.1 General

The Performance Demonstration Program (PDP) for Nondestructive Assay (NDA) is a test program designed to yield data on measurement system and organization capability to characterize transuranic (TRU) waste generated throughout the U. S. Department of Energy (DOE) complex and packaged in a standard waste box (SWB). The tests are conducted annually and provide a mechanism for the independent and objective assessment of NDA system performance and capability relative to the radiological characterization objectives and criteria of the DOE Carlsbad Field Office (CBFO) Office of the National TRU Program (NTP). The primary documents requiring an NDA PDP are the *Transuranic Waste Acceptance Criteria for the Waste Isolation Pilot Plant* (WAC) (DOE/WIPP-02-3122), which requires annual characterization facility participation in the PDP, and the *Quality Assurance Program Document* (QAPD) (CBFO-94-1012). The NDA PDP implements the general requirements of the QAPD and applicable requirements of the WAC.

Measurement facilities must demonstrate acceptable radiological characterization performance through measurement of test samples comprised of radioactive source and surrogate matrix modules configured in an SWB. Facility measurement organizations are required to analyze the NDA PDP SWB samples using the same procedures approved and implemented for routine operational waste characterization activities. The test samples provide an independent means to assess NDA measurement system performance and compliance with criteria specified in the NDA PDP Plan. General intercomparison of NDA measurement system performance among DOE facility measurement organizations and commercial NDA services can also be evaluated using measurement results on similar NDA PDP test samples.

A PDP box test sample consists of an SWB containing waste matrix modules representative of a particular DOE waste category and nuclear material standards of known radionuclide and isotopic composition typical of DOE radioactive material. All PDP SWB configuration box sample components and PDP standards are made available to participating measurement facilities by the CBFO.

The nuclear material type, mass, and associated alpha activity of the NDA PDP radioactive standard sets have been specified and fabricated to allow assembly of NDA Box PDP samples that simulate TRU alpha activity concentrations, radionuclide/isotope distributions, and physical forms typical of the DOE TRU waste inventory. The PDP matrix SWB waste matrix types were derived from an evaluation of information contained in the *Transuranic Waste Baseline Inventory Report* (TWBIR) (DOE/CAO-95-1121) to ensure representation of prevalent waste types and their associated matrix characteristics in NDA PDP testing.

NDA SWB analyses required by the Waste Isolation Pilot Plant (WIPP) may only be performed by measurement facilities and systems that comply with the performance criteria as set forth in the NDA PDP Plan. In this document, these analyses are referred to as WIPP analyses, and the wastes on which they are performed are referred to as WIPP wastes.



## 1.2 Purpose

The purpose of the NDA PDP for boxed waste is to provide independent data on the ability of NDA measurement facilities (including DOE-owned or contracted systems) to meet the data quality objectives for NDA of TRU wastes intended for disposal at WIPP. The CBFO uses the NDA PDP as part of the assessment and approval process for measurement facilities characterizing waste for the NTP. In addition to the NDA PDP, this process includes technical evaluation of NDA measurement system implementation and use, method and performance data supplied by the facility measurement organization, and independent technical quality assurance audits.

This NDA PDP Plan describes the elements comprising the test program, including test apparatus, test sample configuration, and required sample analyses. This NDA PDP Plan also identifies criteria used to evaluate NDA measurement system performance. The Plan further identifies and defines the responsibilities of the program participants, including the NDA PDP Coordinator, the sample preparation team (SPT), the facility measurement organization, and the facility assay coordinator.

The CBFO implements the plan by designating a Program Coordinator (currently the Carlsbad Field Office Technical Assistance Contractor [CTAC]), and by providing program oversight from the CBFO PDP Appointee. The Program Coordinator designates the PDP Manager, who coordinates the three elements of the PDP (headspace gas [HSG], Resource Conservation and Recovery Act (RCRA), and the two-part [box and drum] nondestructive assay [NDA]). In turn, the PDP Manager assigns coordinators to the three PDPs. Each respective coordinator administers and coordinates their respective PDP functions such as PDP sample component preparation, subcontractor oversight, scheduling, scoring, and generating summary reports.

In addition to this NDA Box PDP Plan, there are three other PDP plans: *Performance Demonstration Program Plan for Nondestructive Assay of Drummed Wastes for the TRU Waste Characterization Program* (DOE/CBFO-01-1005); *Performance Demonstration Program Plan for RCRA Constituent Analysis of Solidified Wastes* (DOE/CBFO-95-1077); and *Performance Demonstration Program Plan for Analysis of Simulated Headspace Gases* (DOE/CBFO-95-1076).

## 1.3 Scope and Frequency

Acceptable performance in the NDA Box PDP must be demonstrated initially by all participating facility measurement organizations and systems prior to the analysis of WIPP samples. Subsequently, each facility measurement organization shall be evaluated annually, as specified in the WAC. The primary cycle for NDA Box PDP participation will therefore be annual (i.e., every 12 months, with a one-month grace period). In addition to the primary test cycle, the NDA PDP Coordinator may schedule a supplemental cycle prior to the next annual cycle.

A supplemental NDA PDP cycle can be requested by measurement organizations for systems that have failed one or more NDA PDP samples, for newly implemented systems, or for systems that have been inactive or have undergone changes that could impact the NDA PDP approval status. Requests for a supplemental cycle must be submitted in writing to the CBFO. The CBFO

will consider impacts on the overall WIPP schedule and program costs, and may discuss the request with the potential participants. Timing and selection of measurement facilities for participation in supplemental cycles will be at the discretion of the CBFO. The CBFO will typically require the costs associated with administration of supplemental cycles (e.g., preparation of sample configuration forms, data receipt and scoring, preparation of the scoring report, analysis of any corrective actions identified as required due to system failure) that are requested by the measurement organization be borne by that organization via funds transfer to the PDP Program Coordinator.

Unless a specific exemption is granted by CBFO, NDA facility measurement organization participation in the NDA PDP is required in accordance with the following:

- All NDA systems in use at the time of a scheduled primary cycle must participate in that cycle. If a system does not participate, it will lose its approvals at the end of the 13-month period from the preceding cycle in which it participated.
- Any NDA system unable to participate in the primary cycle can request a supplemental cycle to obtain initial approval, maintain approval, or reestablish approval.
- Every measurement system must go through an initial NDA PDP cycle in order to establish confidence that the system is acceptable to characterize TRU wastes destined for the WIPP. An “initial PDP cycle” includes: 1) the first implementation of an NDA measurement system; 2) initial use after significant modification or recalibration; 3) application of an NDA system to waste forms significantly different than those for which it is approved; and 4) movement to another location. Other circumstances may also merit an initial PDP cycle.
- NDA systems that have successfully participated in the current year primary cycle, and are relocated to a site where no PDP standards and matrix SWB set exist, will be allowed to perform WIPP waste radiological characterizations if the CBFO verifies and approves the system. Documentation on system capability and performance relative to the waste forms at the new site must be submitted to the CBFO for review and approval. The system must have successfully participated in an NDA PDP cycle within the last 13 months.
- NDA PDP acceptance criteria, in addition to other criteria deemed appropriate by the CBFO, will be used to determine initial acceptability of measurement system function and performance prior to use for WIPP waste characterization. During the initial cycle, the measurement system may be subject to more PDP test samples than typically employed in subsequent cycles.
- Inactive NDA systems are defined as approved systems not being used to characterize WIPP wastes. Inactive systems are not required to participate in NDA PDP cycles.
- All systems classified as inactive during a primary NDA PDP cycle must participate in an NDA PDP cycle prior to returning to active status. If the reactivation schedule does not coincide with the next scheduled primary PDP cycle, the owner/operator can petition the CBFO for a supplemental cycle.

The PDP samples must be analyzed using methods the facility measurement organization has implemented or plans to implement for routine analysis of WIPP wastes. Only the methods actually used in the PDP are considered acceptable to support the analysis of WIPP wastes.

#### 1.4 Radioisotopes, Activities, and Waste Matrices

The following primary isotopes are evaluated under the NDA PDP Plan. Of these, the first four are the most significant in terms of WIPP inventory parameters and limits, and are subject to scoring as specified in this plan.

- $^{238}\text{Pu}$
- $^{239}\text{Pu}$
- $^{240}\text{Pu}$
- $^{241}\text{Am}$
- $^{233}\text{U}$
- $^{234}\text{U}$
- $^{238}\text{U}$

The uranium isotopes comprise a significant fraction of the DOE inventory and must be accounted for in the repository assessments, but are not subject to NDA PDP scoring. Only transuranic alpha emitting isotopes are of scoring consideration. National TRU Program PDP standards containing plutonium (powder and granular forms), americium, and depleted and enriched uranium have been specified, fabricated, and distributed to select sites to support NDA PDP program purposes.

The matrix SWBs are used with the PDP standards to create test samples containing matrix materials representative of DOE TRU waste types. These matrix materials are configured within the PDP matrix SWB for each cycle in a manner replicating the nominal properties of an actual waste matrix type for material composition, density, and density distribution. In this manner, the SWB matrix surrogates replicate the physical properties of real waste forms and manifest perturbations in the response of NDA systems, as do actual wastes.

Boxed SWB TRU waste forms present in the DOE inventory comprise a broad spectrum of waste types. To represent this range of waste types, four different SWB waste matrix types were specified and fabricated. PDP SWB matrix material types were derived from the DOE inventory of SWB containers, as well as the projected material types to be placed in the SWB waste containers. The material properties of these categories were considered in terms of their respective effects on NDA technologies and subsequently condensed to four matrix types: non-interfering matrix (empty), combustibles, mixed metals, and concrete debris.

## 2.0 PROGRAM COORDINATION

### 2.1 General Responsibilities

The CBFO is the review and approval authority for the NDA PDP for boxed DOE waste. Programmatic direction and oversight of the PDP are performed by the NTP, which manages the PDP on behalf of the CBFO. The NTP is part of the Office of Operations. Figure 1 summarizes the organizational flow of the NDA PDP program.

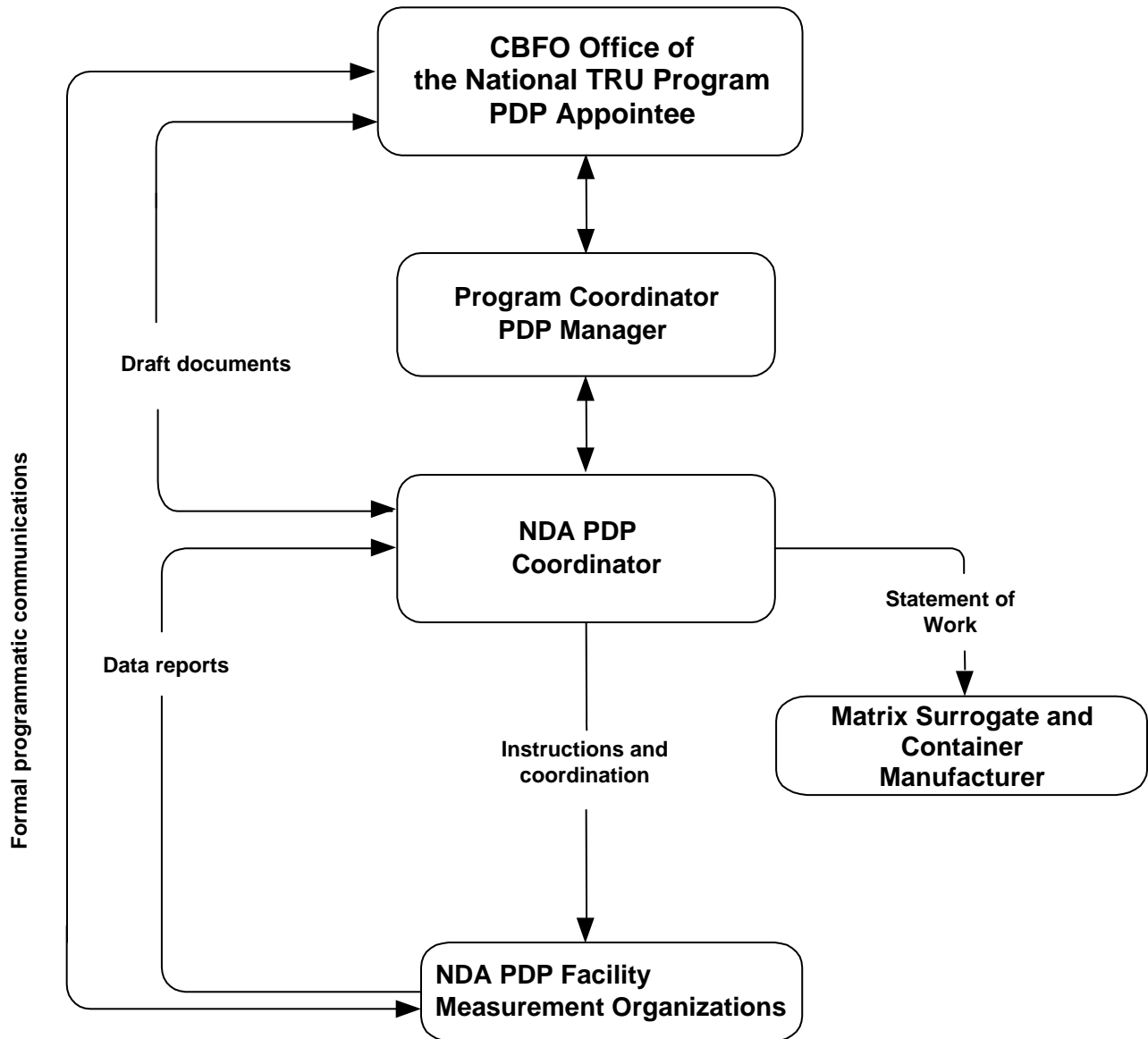

Figure 1. Organization and Communication Flowchart for the NDA PDP

A CBFO-designated organization functions as the program coordinator and technical advisor to the CBFO. Within the organization, the PDP designates an individual that operates as the coordinator of the NDA portion of the PDP. This NDA PDP Coordinator must comply with the responsibilities stipulated in this plan in accordance with the requirements of the CBFO *Performance Demonstration Program Management Plan* (DOE/CBFO-01-3107). The NDA PDP Coordinator is responsible for the following activities:

- Distributing and tracking PDP standards and matrix SWBs and matrix modules as appropriate to implement the program.
- Maintaining documentation on all NDA PDP standards and matrix SWBs, matrix modules, and associated components.
- Confirming the schedule of a primary NDA PDP cycle at least 2 weeks before the planned start date.
- Distributing NDA PDP sample preparation instructions and associated materials.
- Ensuring training for the on-site SPTs is in accordance with the NDA PDP Plan.
- Collecting and scoring NDA PDP sample data reports from the facility measurement organizations.
- Preparing cycle-specific, facility measurement organization-specific, measurement system-specific, sample-specific scoring reports.
- Ensuring that records of participation and results of all NDA PDP cycles are adequately maintained in a retrievable condition.
- Reviewing changes in the QAPD or WAC that affect this plan and revising the plan as appropriate, with CBFO direction and approval.
- Assisting in the resolution of disputes related to NDA system measurement results, test sample configuration, operational restrictions, and other issues that may arise during an NDA PDP test cycle.
- Developing technical recommendations to the CBFO regarding conditional NDA characterization approvals related to NDA PDP performance.
- Maintaining a current register of participating facility measurement organizations and their measurement system registrations. The registration documentation contains information on each assay system including a unique identity, measurement principles and modes, the NDA PDP test combinations permitted under facility measurement organization/system-specific calibration, and administrative limits.
- Ensuring the NDA PDP test material inventory at each site is sufficient to support cycle implementation.
- Procuring NDA PDP components to replace lost or damaged parts as necessary.

The CBFO grants approval for each facility measurement organization/NDA system participating in the NDA PDP. Organizations/systems that are not current participants may petition the CBFO to participate in the PDP. Participation by measurement system organizations not actively engaged in characterization of TRU wastes for WIPP-related programs is at the discretion of the CBFO.

## **2.2 Facility Measurement Organization Contacts and General Responsibilities**

Each participating facility is required to provide the NDA PDP Coordinator, in writing or by e-mail, with the name, telephone number, fax number, and address of a single contact person (assay coordinator) responsible for on-site administration and conduct of the NDA PDP (e.g., cycle-specific schedules and instructions). The assay coordinator is to be a full time employee or subcontractor of the facility. The assay coordinator is responsible for ensuring necessary communication, verbal and/or written, with the NDA PDP Coordinator regarding all aspects of the conduct of a given NDA PDP cycle.

The participating facility is also required to provide a contact and address suitable for freight and package delivery of the NDA PDP components, NDA PDP standards, and replacement parts. Such information shall be supplied in writing or e-mail each time the contact personnel change.

Each participating facility is required to provide the NDA PDP Coordinator, in writing or by e-mail, the inventory and location of all PDP materials (standards, SWBs and parts) once per year. The NDA PDP Coordinator will request the inventory each January and will make periodic requests to help the participating facility meet their requirement. A description of the condition of the PDP sample components is also required of the facility (e.g., tamper indicating device (TID) security lanyard and locating pin condition). Digital images of the NDA PDP sample components can be submitted in lieu of condition descriptions. Any changes in personnel should be noted along with the inventory.

Participating facility measurement organizations must complete a registration form for each measurement system to be tested in the NDA PDP to establish its identification, calibration range, operational limits, and other administrative information affecting NDA PDP testing. Measurement systems must be registered for each facility measurement organization (some DOE sites have multiple measurement facilities and organizations) such that the registration is unique to the application of that system for a specific facility measurement organization. Appendix A contains the necessary forms and instructions for registering a system for the NDA PDP.

## **2.3 Program Assessment**

The NDA PDP is routinely assessed for utility and effectiveness through several interrelated activities. These activities include the CBFO's review of the test results for each NDA PDP cycle; approval of this plan; consideration of the reports and observations of the Program Coordinator, PDP Manager, and NDA PDP Coordinator; feedback from program participants; and comments from other parties such as independent quality assurance (QA) assessors. Records of comments, decisions, or proposed actions resulting from the CBFO assessment may take any documented form including, but not limited to, routine program correspondence, meeting

minutes, action items, formal review of program documents, assessment reports, and corrective actions.

## **2.4 Procurement**

Procurement activities necessary for conducting the NDA PDP must comply with the QAPD. In accordance with the QAPD, the responsible purchasing organization maintains all procurement documents and performs all procurement activities.

## **2.5 Training**

Each organization involved in the implementation of the NDA PDP shall meet the training requirements of the QAPD. Organizations shall retain on file evidence that: 1) personnel have the necessary program documents (controlled or uncontrolled, as applicable) for their use; and 2) personnel have read and understand program-governing documents pertinent to their duties in support of the NDA PDP. At a minimum, these documents include applicable portions of the QAPD, the WAC, and this plan.

### **3.0 PREPARATION AND DISTRIBUTION OF RADIOACTIVE STANDARDS AND SWB MATRIX BOXES**

#### **3.1 Overview**

The CBFO is responsible for the specification and procurement of NDA PDP standards. An NDA PDP standard is defined as a radioactive source specifically designed, prepared (or acquired), and certified for the NDA PDP. The NDA PDP standards have pedigrees traceable to nationally recognized reference bases such as the National Institute of Standards and Technology. To date, all standards used in the NDA PDP have been manufactured at the Los Alamos National Laboratory. However, sources with appropriate traceability and certification from other programs or commercial sources may be used. The types of radioactive NDA PDP standards presently in the NDA PDP inventory are listed in Table 1.

The CBFO is also responsible for the specification and procurement of PDP SWB matrix boxes and associated components for use in the NDA Box PDP. A PDP matrix box is a modified SWB containing a set of 60 matrix modules that are installed into the box in a specified manner. The installed array of matrix modules contains 24 vertical pass-through holes to allow insertion of PDP standards at known coordinates. Details regarding the design and intended use of the NDA PDP SWB matrix boxes can be found in the specification document associated with each matrix type (INEEL/EXT-02-01271, INEEL/EXT-02-01272, INEEL/EXT-02-01273, INEEL/EXT-02-01274, INEEL/EXT-03-00535).

NDA PDP standards, matrix boxes, and matrix box components are not to be used for system calibration under any circumstances. The use of these components for any activity other than conduct of the NDA PDP cycle, as specified by the NDA PDP Coordinator, must have prior written approval from the CBFO.

#### **3.2 PDP Radioactive Material Standards**

The external dimensions of the PDP standards are compatible with PDP SWB matrix box source insert fixtures that provide for the secure and accurate placement of standards within the SWB matrix module array. Refer to Appendix B for the general specifications of the PDP radioactive standards currently inventoried. Detailed information and data concerning the specification, design, fabrication, and traceability for each NDA PDP standard manufactured in each production phase is provided in its respective production plan document (LAUR-96-2277, LAUR-98-213, LA-CP-00-54, LA-CP-00-110, LA-CP-01-208, LA-CP-03-0072, LA-CP-03-0763). As indicated in Table 1, seven different PDP standard production campaigns were completed, each producing NDA PDP standards with differing nuclear material content.



Table 1. NDA PDP radioactive standard inventory.

Type of Activity	Production Phase
1. Weapons-grade plutonium (low mass set)	Phase I
2. Weapons-grade plutonium (high mass set)	Phase II.A
3. Large particle size weapons-grade plutonium	Phase II.B
4. Enriched uranium	Phase II.C
5. Depleted uranium	Phase II.D
6. Increased Am/Pu ratio (relative to the native quantity in weapons-grade plutonium)	Phase III.A
7. Heat source plutonium	Phase III.B

### 3.3 PDP Surrogate Waste Matrices and Boxes

The NDA PDP SWB matrix inventory consists of five separate boxes: two (2) dry combustibles matrix module sets; two (2) mixed metals type matrix module sets; and one (1) concrete debris matrix module set. Identifying serial numbers are assigned and affixed to each SWB matrix module box. Two of the SWB box types are differentiated as the matrix configuration box and the matrix module storage box. The configuration box contains an elaborate SWB floor reinforcement structure that provides for the installation and correct positioning of the matrix module array and NDA PDP standard insert fixtures. The configuration box contains additional internal components to secure the matrix/source array in place to prevent configuration shifts during movement and measurement of the SWB PDP sample. The configuration box also has provisions for the attachment of TIDs to ensure the integrity of the sample during the test process. The matrix storage box has none of these added features and cannot be utilized as a configuration box.

Below is a list of the NDA PDP matrix boxes by serial number and matrix type. Note that the configuration box was used to ship a set of modules and therefore will have the serial number assigned to that given matrix module set. The configuration box also serves as a storage box when the SWB matrix modules shipped with it are not in use.

- Serial# NDA PDP-SWB-01 (configuration box, originally for combustibles)
- Serial# NDA PDP-SWB-02 (configuration box, originally for combustibles)
- Serial# NDA PDP-SWB-03 (storage box only, originally for mixed metals)
- Serial# NDA PDP-SWB-04 (storage box only, originally for mixed metals)
- Serial # NDA PDP-SWB-05 (configuration box, originally for concrete)

Refer to Appendix C for general information on the PDP SWB matrix box design and configuration. Detailed information regarding the specification, design, and as-built data on the NDA PDP matrix boxes is provided in the documents referenced in Section 3.1.

### 3.4 PDP Sample Component Control and Use

The NDA PDP Coordinator shall ensure delivery of the appropriate set of NDA PDP standards and SWB matrix boxes to each facility prior to that facility's participation in NDA PDP measurement activities. The NDA PDP Coordinator shall ensure that any lost or damaged PDP components are replaced to prevent delay of an NDA PDP cycle. The facility custodial organization is responsible for assigning a secure storage area for all NDA PDP components and meeting applicable safeguards, security, and safety requirements. No one is authorized to disassemble or modify any PDP SWB matrix component without the express, written permission of the NDA PDP Coordinator.

Without written CBFO permission, SWB matrix boxes/modules or NTP standards are not to be used for any activity other than the performance of the NDA PDP. Requests for any other uses must be submitted to the CBFO in writing for each specific use requested. CBFO will provide written approval or disapproval of the request. Under no circumstances are the NDA PDP standards to be used for measurement system calibration.

Before shipment of NDA PDP standards, each participant will make appropriate arrangements with the facility's safeguards and radiation safety organizations for storage and accountability. The SPT will coordinate with the site safeguards staff to comply with all site special nuclear material (SNM) requirements. At the time of receipt, the assay coordinator and/or SPT assigned by the facility measurement organization shall inspect, inventory, and secure the PDP standards, and will perform inspection of the SWB matrix boxes, associated modules and ancillary components for defects or damage.

The NDA PDP Coordinator shall coordinate any transfers of NDA PDP standards between sites and no such movement will occur without written approval from CBFO. The NDA PDP Coordinator will provide the transferring facility with the necessary contact information (names, phone numbers, e-mails, and physical addresses) for the receiving facility (e.g., another participating site). The current custodian will notify each site contact prior to the shipping date for PDP standards and/or SWB matrix boxes and associated components. The NDA PDP Coordinator will, through careful coordination with the sending facility, ensure proper palleting and packaging of the PDP SWB components prior to shipping. The PDP standards will be sent to the address and individual designated by the receiving facility. The assay coordinator at each site shall notify the NDA PDP Coordinator in writing (e-mail is acceptable), of any changes in contact personnel.

#### 3.4.1 PDP Sample Components Receipt

On receipt of NDA PDP standards and/or SWB matrix boxes and components, the assay coordinator and/or the SPT shall:

- Verify that the serial numbers and physical descriptions of the NDA PDP standards, SWB matrix boxes, and associated components received match those listed on the shipping manifest. The PDP SWB matrix boxes will need to be opened to ensure the matrix modules are included in the shipment as indicated in the manifest. If applicable, the ancillary component storage box must also be opened to verify the content and quantity of items.

- Verify that the SWB box, modules, and ancillary components have not been damaged during shipping. Where shipping manifest discrepancies are noted or damage is found, the assay coordinator and/or the SPT shall secure the items and the assay coordinator and/or the SPT shall notify the NDA PDP Coordinator. If no discrepancy or damage is found, the assay coordinator shall notify the NDA PDP Coordinator in writing or by e-mail, that the shipment was received in acceptable condition.
- The assay coordinator and/or SPT will ensure all NDA PDP components are properly stored and controlled to prevent unauthorized use, loss, or damage. Proper storage includes indoor, controlled climate (e.g., heated space), protection from exposure to water, and protection from physical damage (e.g., stacking on top of boxes, forklifts). Security is to be maintained on all NDA PDP standards. NDA PDP standards and PDP SWB matrix boxes and modules are only to be used for NDA PDP purposes unless written permission has been granted by CBFO for other purposes. Questions concerning permissible use shall be referred to the CBFO or the NDA PDP Coordinator.

### 3.5 PDP Sample Components Condition Control and Repair

All NDA PDP components must be maintained in a controlled and consistent condition in which they were provided to the participant. Any repairs to PDP SWBs or component parts must be arranged with the NDA PDP Coordinator. **Under no circumstances should any modifications be performed on the NDA PDP standards.** If minor repairs to SWBs and related materials are needed, the facility may make those repairs with NDA PDP Coordinator approval. When required, replacement parts will be provided by the NDA PDP Coordinator. Any significant repair will require that the SWB or component be returned to the NDA PDP Coordinator.

## 4.0 TEST SAMPLE PREPARATION

### 4.1 Responsibilities

A two-person SPT, consisting of a PDP standards custodian and a PDP standards configuration attestant, shall be assigned by each facility measurement organization. The assay coordinator may serve as a member of the SPT as long as independence from the measurement process is maintained. The SPT members must, at a minimum, possess the following qualifications and experience:

1. Full-time employee or subcontractor of the facility where NDA PDP materials are maintained.
2. Independent of the measurement group being tested; that is, neither member of the SPT or assay coordinator may participate in assay measurements of NDA PDP samples that they have prepared.
3. QA trained, including applicable site QA training and the training provided through the NDA PDP program for SPT members.
4. Qualified to handle radioactive materials (PDP standards custodian only).

The PDP standards custodian and/or assay coordinator is responsible for coordinating on-site activities with safeguard organizations, radiation safety, and NDA PDP facility measurement organization contacts. These activities include, but are not limited to, NDA PDP standard receipt, storage, and retrieval, control of stored components (e.g., PDP matrix SWBs and modules, insert fixtures, and matrix spacers), NDA PDP sample preparation, and NDA PDP sample disassembly. During the conduct of an NDA PDP cycle, the PDP standards custodian or assay coordinator notifies the NDA PDP Coordinator should any issue develop regarding the use, control, and condition of the NDA PDP samples and ancillary items.

The PDP standards configuration attestant is responsible for verifying the proper placement of NDA PDP standards within the insert fixture and SWB matrix module array, as well as security-related or other procedures associated with sample preparation. The PDP standards configuration attestant is responsible for ensuring that operations executed by the PDP standards custodian are performed in accordance with the SWB test sample preparation instructions supplied by the NDA PDP Coordinator. To perform these functions, the PDP standards configuration attestant witnesses all NDA PDP standard-loading operations and sealing of the configured SWB test sample box using serial-numbered NDA PDP TIDs provided by the NDA PDP Coordinator. The assay coordinator and/or SPT are responsible for the integrity of each prepared NDA PDP sample from the time it is sealed until disassembly at the conclusion of the cycle. Other than the SPT or assay coordinator, no observers are permitted during the PDP sample preparation process without the prior permission of the NDA PDP Coordinator. The assay coordinator and/or SPT shall not divulge any information regarding the loading and configuration of the PDP SWB box test sample until the measurement results are released by the CBFO or as indicated by the NDA PDP Coordinator.

#### **4.2 NDA PDP Sample Preparation Instructions**

At least two weeks prior to the scheduled start date of a primary NDA PDP cycle, the NDA PDP Coordinator shall forward a letter of instruction to each facility assay coordinator for the SPTs that are servicing the participating facility measurement organizations. This letter will specify the serial number of the SWB, SWB matrix module type(s), module load pattern, the identification and insert fixture position of each PDP standard, and the position of each insert fixture within the matrix module array for the cycle. This information is supplied on the NDA PDP sample configuration form for nondestructive assay (see Appendix D). For a primary NDA PDP cycle, the date the cycle commences is specified in the instructions provided to the assay coordinator. Measurement result report forms (see Appendix D) must be received within 28 days of the cycle start date unless an extension is requested from CBFO, by the participating measurement organization, in writing and granted as described further in Section 5.2.

When a supplemental cycle is conducted, the instructions will be sent by the NDA PDP Coordinator to the facility assay coordinator. Within five working days of receipt of the instruction package, the assay coordinator must check the package for completeness and e-mail verification of receipt to the NDA PDP Coordinator. The date this verification is received by the NDA PDP Coordinator commences the measurement and reporting period for the supplemental NDA PDP cycle. Measurement result report forms must be received by the NDA PDP Coordinator within 28 days of the cycle start date unless an extension is requested from CBFO by the participating measurement organization in writing, and granted as described further in Section 5.2.

The following steps are repeated for the preparation of each PDP sample specified for a given cycle:

1. The SPT shall identify the correct NDA PDP standards using the applicable PDP Standard Configuration Form for SWB (Appendix D). The standard configuration form, in conjunction with the PDP Matrix Configuration Form for SWB (Appendix D), provides the SPT with both the SWB matrix module array and the PDP standard placement within the array. The SPT shall select the proper serial-numbered configuration SWB (not storage SWB) for installation of NDA PDP standards and matrix spacers. The PDP standards configuration attestant shall verify that the proper SWB is selected for PDP standard loading.
2. The SPT shall identify each matrix module that will be used to assemble the SWB matrix array, including void modules, per the sample PDP Matrix Configuration Form for SWB (Appendix D). The PDP standards configuration attestant shall verify that the proper SWB matrix modules and insert fixture matrix spacers were selected for PDP standard loading. The empty SWB sample is produced by installing NDA PDP standards into a configuration box using the source insert fixtures and internal support structure, with no matrix modules.
3. The SPT shall coordinate the placement of the PDP SWB matrix configuration box, matrix modules, matrix spacers, NDA PDP standards, and related equipment (such as TIDs) into a designated sample preparation area.
4. The SPT shall examine all required PDP sample components (e.g., SWB configuration box, matrix modules, NDA PDP standards, matrix spacers) per the PDP sample configuration form. The purpose of the pre-load examination is to determine if any components are missing or damaged.

**NOTE:** If a damaged or missing PDP sample component is identified, the SPT and/or assay coordinator shall take appropriate action as follows, depending on the component:

- Notify the NDA PDP Coordinator of any PDP component loss or damage. If the component is a consumable item (such as a TID, form, insert tube, or matrix spacer), determine if a spare component is available from the site inventory. If so, replace the missing or damaged component with the spare, document the replacement as appropriate, and notify the NDA PDP Coordinator of the replacement.
  - If a spare component is not available in inventory, or if the missing or damaged item is an NDA PDP radioactive standard, SWB configuration box, or SWB matrix module, the PDP standards custodian, through or in conjunction with the assay coordinator, will immediately notify the NDA PDP Coordinator. The SPT shall secure all materials and await further instructions.
5. The SPT shall assemble the SWB matrix module array per the instruction sheets provided by the NDA PDP Coordinator.

6. The PDP standards custodian will load each insert fixture with NDA PDP standards per the PDP Standard Configuration Form for SWB (Appendix D) and insert each loaded insert fixture into the identified SWB matrix module pass-through hole as specified on the PDP Matrix Configuration Form for SWB (Appendix D). Matrix module installation and NDA PDP standard installation shall be verified by the PDP standards configuration attestant as correct, and subsequently documented by initialing the specified box of the PDP Standard Configuration Form for SWB (Appendix D).
7. Once all SWB matrix modules and NDA PDP standards have been verified as properly positioned per the sample configuration instructions, the PDP standards configuration attestant shall affix the appropriate serialized TIDs on the SWB configuration box lids, thereby sealing and securing the test sample for the measurement process.
8. The PDP standards custodian shall seal the envelope containing a copy of the completed PDP Standard Configuration Form for SWB (Appendix D) with a tamper-indicating security seal and affix it to the PDP SWB sample box. A site-specific sample information form may accompany this copy of the PDP sample configuration form if a specific form is required by the site staff responsible for SNM accountability. The sample configuration form that has been sealed in the envelope provides relevant NDA PDP standard information, including standard activity and standard location within the SWB matrix box in the event it is needed in an emergency situation. The configuration form may be opened only during an emergency or at the time of sample disassembly. If the security seal for the PDP sample configuration form is broken before PDP sample disassembly at the conclusion of the cycle, the NDA PDP Coordinator is to be notified and analysis data for that sample may be considered invalid.
9. The SPT shall return any unused Box PDP materials to storage and secure the NDA PDP standards storage area with a TID. A site-specific security system may be used in place of the supplied TID as long as the prevention of unauthorized access to the unused standards or storage-related documentation can be ensured and documented.
10. The SPT shall prepare a PDP Sample Custody Form for Nondestructive Assay (Appendix D) for transfer of the sample to the facility measurement organization. The NDA PDP standards custodian shall transfer the PDP samples and custody forms to the measurement organization by obtaining the signature of the measurement organization's responsible individual for each prepared PDP sample.

If multiple assay systems are to be qualified at one site or facility, it is the assay coordinator's responsibility to oversee and manage schedules and PDP sample transfers between the various assay systems at the site. If there is not enough time to make all measurements for the number of participating assay systems, the assay coordinator or representative of the responsible measurement organization should request an extension to the cycle pursuant to Section 5.2.

The SPT and/or assay coordinator shall maintain all records of PDP sample preparation in strict confidence until CBFO distributes a final report, or as notified by the NDA PDP Coordinator.

## **5.0 ANALYTICAL AND DATA REPORTING REQUIREMENTS**

This section describes required activities for NDA PDP sample acceptance, analysis, and return to the SPT when measurements are complete. This section also describes requirements for reporting measurement results data to the NDA PDP Coordinator.

### **5.1 NDA PDP Sample Receipt and Custody**

The participating measurement organization's representative is responsible for accepting PDP samples, ensuring adherence to chain-of-custody protocols, and confirming the accuracy of each sample custody form.

On initial receipt of a PDP sample, the measurement organization representative shall inspect the condition of the sample seals by checking the TIDs and ensuring they are intact. If a problem exists with the integrity of a TID, the measurement organization representative shall not accept the sample from the SPT member. If an NDA PDP sample is rejected due to TID integrity issues, the SPT shall return the sample to the sample preparation area, confirm the sample integrity, re-apply new TID devices, and return the sample to the measurement organization representative. If the PDP sample does not leave the custody of the SPT between sample preparation and identification of the TID issue, a new TID may be placed on the NDA PDP SWB without compromising the sample integrity.

Provided that the TIDs are intact and the sample custody forms are properly completed, the measurement organization representative shall review, sign, and date the sample custody form. This custodial signature means that the measurement organization accepts the PDP sample for analysis. The SPT makes and retains a copy of the custody form for each sample.

All subsequent transfers of the PDP sample within the measurement group and ultimate return to the SPT shall be documented on the PDP sample custody form accompanying the PDP sample. The final signature on the custody form is to be made by the SPT when the PDP sample is accepted for disassembly at the conclusion of assay system measurements.

### **5.2 Analysis**

The facility measurement organization shall perform six (6) analyses of each PDP sample using the assay procedures that are implemented for routine waste assays, and approved for use in the WIPP waste characterization program. These procedures must have been reviewed and approved by CBFO. The PDP sample must be completely removed and replaced between each sequential measurement. The PDP sample shall be analyzed six (6) times only. It is not permissible to select six (6) measurements from a larger measurement set and submit them as the NDA PDP cycle measurement replicate set. Analyses should be completed and reported as soon as possible, except in cases where one or more of the six (6) replicates are judged by the NDA analyst to be defective due to instrument failure or operator error. Identification of instrument failure or operator error should be based on the methods used by the measurement organization in identifying these issues when analyzing WIPP samples rather than by reviewing NDA PDP data and determining accuracy and precision issues exist. If instrument failure or operator error can be identified in accordance with approved procedures, the NDA PDP Coordinator is to be notified.

Based on circumstances, the NDA PDP Coordinator may give permission to re-analyze the six-replicate set prior to submitting data on the Nondestructive Assay Performance Demonstration Program Report Forms (Appendix D).

If a participant's analyses will not be reported by the due date, the CBFO and the NDA PDP Coordinator must be notified in writing (e-mail is acceptable) as soon as possible, and the participant must request a time extension. Extensions must be requested before the due date, and will be granted or denied in writing by the CBFO. When granted, the extension approval will designate a new due date for data receipt. If an extension has not been requested prior to the applicable due date (i.e., either the original due date or any subsequently granted extended due date), the NDA PDP Coordinator may make known the identity and concentration of the content of the PDP samples at any time after the due date. Any participant that has not yet reported will be unable to submit the data for scoring in that NDA PDP cycle, unless other arrangements have been made with the NDA PDP Coordinator.

### **5.3 Reporting**

The participating facility measurement organization data report forms shall contain those isotopes identified from the list in Section 1.4, for each replicate analysis. The activity of each isotope detected and quantified must be reported. If the test sample is below the minimum detectable concentration (MDC) or outside the calibration range of the measurement system, measured values are not required in the report, only the reason for no value (e.g., <MDC).

A signed measurement report for each replicate analysis of each PDP sample shall be forwarded directly to the NDA PDP Coordinator. The due date for all analytical reports to be received by the NDA PDP Coordinator will be 28 calendar days after receipt of instructions (except as noted in Section 5.2).

#### **5.3.1 Report Contents**

To submit NDA PDP sample measurement results, an NDA PDP report form is required for each individual replicate analysis. The Performance Demonstration Program Report Form - Nondestructive Assay (Appendix D) should be used to report the data to the NDA PDP Coordinator. Continuation sheets may be used if facility measurement organization comments exceed the allotted space. Completed forms shall be signed by a facility measurement organization staff member responsible for transfer of the results to the NDA PDP Coordinator. Reports should contain any other sample measurement information deemed relevant by the facility measurement organization. Corrections to data, or data inadvertently omitted from the report form will be accepted, with adequate and acceptable justification, if the NDA PDP Coordinator is notified before the cycle scoring report is issued.

Each NDA PDP report form must contain, at a minimum, the following information for each determination:

- Identification of the reporting facility measurement organization, including system ID obtained from the NDA PDP registration process
- Identification of the PDP cycle for which the data are being reported



- Identity of the NDA PDP Sample ID from the PDP Sample Custody Form for Nondestructive Assay
- Identification of the measurement system and method (including software/hardware configuration version) used for each isotope (measurement systems using constant isotope ratios are to be indicated on the report form)
- Identification of the NDA PDP sample measurement replicate number corresponding to the analytical data
- Identity and activity in curies for each isotope identified and quantified
- Total uncertainty for each identified isotope at one standard deviation
- Total <sup>239</sup>Pu fissile gram equivalent (g) and associated total uncertainty at one standard deviation
- Total TRU alpha activity and associated total uncertainty (curies) at one standard deviation
- Thermal power and associated uncertainty at one standard deviation (W)
- Elapsed counting time
- Date and time of sample analysis

### 5.3.2 Analytical Records

Records generated by the NDA PDP Program and participating sites during the conduct of a PDP cycle are QA records. All NDA PDP cycle documentation must be maintained in a traceable and auditable condition. Storage conditions and duration must meet the requirements of the QAPD and other implementing QA documents and procedures.

## 5.4 Completion and Disassembly

After the replicate measurement sets are complete and the PDP sample(s) are returned from the assay coordinator, the SPT is authorized to disassemble the PDP samples at the site's convenience. The PDP samples shall be disassembled in the following manner.

- The PDP standards custodian shall retrieve the appropriate PDP Sample Custody Form for Nondestructive Assay, PDP Standard Configuration Form for SWB, and PDP SWB Matrix Configuration Form for each PDP sample to be disassembled (Appendix D).
- The PDP standards custodian shall determine the condition of the TID that seals the copy of the PDP SWB Standard Configuration Form (Appendix D) attached to the SWB sample. If the seal is broken, the PDP standards custodian shall contact the assay coordinator, who will evaluate and notify the NDA PDP Coordinator. If the seal is not already broken, the PDP standards custodian will break the security seal and remove the standard configuration form from the SWB PDP sample. If the security seal for the PDP standard configuration form is compromised before PDP sample disassembly, all analysis data for that sample may be considered invalid. In such an event, the PDP standards

custodian shall notify the NDA PDP Coordinator, through or in conjunction with the facility assay coordinator, for determination of measurement data validity.

- The PDP standards custodian shall determine the condition of the TIDs on the SWB lids that prevent tampering with the test sample. The PDP standards custodian will break the TIDs, allowing removal of the SWB lids and PDP standard insert fixtures. If one or more of the TIDs is broken before PDP sample disassembly, the PDP standards custodian shall notify the NDA PDP Coordinator, through or in conjunction with the assay coordinator, for determination of measurement data validity. If any TID, custody seal, SWB lid, or standard shows evidence of tampering, the PDP standards custodian shall ensure that the evidence of tampering is secured and that the condition is noted on the custody form.
- The PDP standards custodian shall remove each NDA PDP standard from the source insert fixture. Each SPT member shall then independently assess the source positioning. The appropriate box is then checked and if the positioning was incorrect, the difference is documented in the “Condition” column of the Disassembly Form. Finally, both the PDP standards custodian and the PDP standards configuration attestant sign and date the Disassembly Form. If a PDP sample component is damaged, missing or misplaced, this information must be reported to the assay coordinator, who will evaluate the situation and notify the NDA PDP Coordinator.

Once all PDP standards have been removed, the standards custodian will coordinate the return of the SWB PDP configuration box with matrix modules and the PDP sample standards to the designated, secured storage area using the facility's normal storage procedures. At completion of the disassembly operations, the PDP sample custody forms “Disposition” section shall be noted as “Disassembled.” The original signed NDA PDP Sample Configuration Forms, the NDA PDP Sample Custody Forms, and the Sample Disassembly Forms are required QA records and must be returned to the NDA PDP Coordinator.

## 6.0 EVALUATION OF PERFORMANCE DATA

In the NDA PDP, measurement system performance is evaluated using measurement data precision and bias. Precision is defined as the percent relative standard deviation (%RSD); the standard deviation of the six sequential replicate measurements divided by the known value times 100%. Bias is the systematic error component of the total measurement uncertainty determined as the ratio of the mean of the measurement replicate set to the known value times 100%, or the percent recovery (%R).

The precision acceptance criteria vary as a function of the activity range of the sample and whether the NDA PDP sample matrix is considered to be interfering or non-interfering. The bias acceptance range does not vary as a function of sample alpha ( $\alpha$ ) activity but does vary as a function of sample matrix category. Categorized  $\alpha$  activity ranges that apply to the NDA PDP data acceptance criteria are listed in Table 2.

The scoring system for the NDA PDP is pass-fail. In order to pass an NDA PDP test cycle, the measurement results must meet the acceptance criteria for both precision and bias listed in Table 2. Both precision and bias are measured for all NDA PDP samples.

Table 2. NDA PDP activity ranges and associated scoring acceptance criteria.

Activity range	Range of sample activity in $\alpha$ -curies <sup>a</sup>	Maximum Measured Precision <sup>b</sup>		Bias Range <sup>c</sup> (%R <sub>L</sub> and %R <sub>U</sub> )	
		Non-interfering matrix (%RSD)	Interfering matrix (%RSD)	Non-interfering matrix (%R)	Interfering matrix (%R)
Low	> 0 to 0.02	14	16	Lower: 70 Upper: 130	Lower: 40 Upper: 160
Mid-Low	> 0.02 to 0.2	10.5	12	Lower: 70 Upper: 130	Lower: 40 Upper: 160
Mid-High	> 0.2 to 2.0	7	12	Lower: 70 Upper: 130	Lower: 40 Upper: 160
High	> 2.0	3.5	6	Lower: 70 Upper: 130	Lower: 40 Upper: 160

%R = percent recovery

%RSD = percent relative standard deviation

- Applicable range of TRU activity contained in a PDP sample; units are curies of alpha-emitting TRU isotopes with half-lives greater than 20 years.
- Measured precision that must be met to satisfy the precision criteria at the 95% upper confidence bound, based on six replicates. The values are one relative standard deviation referenced to the known value for the test.
- %R<sub>L</sub> and %R<sub>H</sub> values used in Equation 3 to determine the 95% confidence bound for the ratio of the mean of the measured values to the known value, expressed as a percent.

Different criteria have been established for PDP SWB matrix categories distinguished as non-interfering and interfering. A measurement system’s precision and bias for the non-interfering matrix is evaluated from measurements on the non-interfering (empty) matrix SWB. The evaluation of a measurement system’s precision and bias for all NDA PDP SWBs containing simulated waste matrices uses the criteria for interfering matrices. See Appendix E for an explanation of the statistical basis for the precision and bias acceptance criteria.

### 6.1 Scoring the Test Data Precision

*Purpose:* To demonstrate compliance with the NDA PDP data acceptance criteria for precision, NDA measurement results from six replicate analyses of an NDA PDP sample of known total TRU  $\alpha$ -activity and known matrix category (i.e., interfering or non-interfering) are used to determine measurement system precision.

*Criteria:* The results reported for total TRU  $\alpha$ -activity from the six replicate measurements of an NDA PDP sample shall not exceed the allowable %RSD of Table 2, column 3 for the non-interfering matrix samples, or column 4 for the interfering matrix samples.

*Method:* The analytical results from the six replicate measurements of an NDA PDP sample are used to calculate the %RSD:

$$\%RSD = 100\% \times \frac{1}{\mu_0} \sqrt{\frac{1}{n-1} \sum_{i=1}^n (x_i - \bar{x})^2} \quad \text{(Equation 1)}$$

where:

- $x_i$  = replicate sample value
- $n$  = replicate sample value
- $\mu_0$  = actual known PDP sample value
- $\bar{x}$  = replicate sample mean, defined by

$$\bar{x} = \frac{1}{n} \sum_{i=1}^n x_i \quad \text{(Equation 2)}$$

The measured %RSD is compared with the applicable limits listed in Table 2. If the %RSD value determined from the measurement data is less than or equal to the matrix-type and total TRU  $\alpha$ -activity range-specific value in Table 2, column 3 or 4, the measurement system passes the precision test for that sample.

*Actions:* Any sample for which results exceed the appropriate acceptance criterion for precision will be scored as failed. The impact of failing an acceptance criterion is given in Section 6.3. In accordance with Section 7, the site project manager is responsible for ensuring that appropriate corrective actions are taken, if deemed necessary by the facility measurement organization or, subsequently, by CBFO.

### 6.2 Scoring the Test Data Bias

*Purpose:* NDA results for replicate analyses for NDA PDP samples of known TRU  $\alpha$ -activity and known matrix category (i.e., interfering or non-interfering) are used to determine the bias

associated with measurement system determinations of total TRU  $\alpha$ -activity. In the NDA PDP, the total bias determined using the six replicate measurement results includes components attributable to both variance and bias, including effects due to sample matrix configuration and nuclear material characteristics.

*Criteria:* The results reported for total TRU  $\alpha$  -activity shall not deviate from the reference or known PDP sample value ( $\mu_0$ ), by more than the amount determined using Equation 3 in conjunction with the appropriate %R<sub>L,U</sub> values specified in column 5 or 6 of Table 2. The selection of the appropriate criteria specified in Table 2 is based on the matrix category (i.e., interfering or non-interfering) but does not vary with activity level.

*Method:* Measurement system bias shall be evaluated by calculating the sample mean of the six sequential replicate measurements of the NDA PDP sample.

For evaluation of sample-specific measurement system bias limits, the Student's *t*-distribution  $t_{0.975}$  percentile value is used in conjunction with the sample mean ( $\bar{x}$  as defined in equation 2), the percent relative standard deviation (%RSD of the sample replicates as defined in Equation 1) and the appropriate lower and upper bounds (%R<sub>L</sub> and %R<sub>U</sub>) in columns 5 and 6 of Table 2. The equation that establishes the bias range acceptance criteria is expressed as:

$$(\%R_L + 1.049 \times \%RSD) < \left( 100\% \times \frac{\bar{x}}{\mu_0} \right) < (\%R_U - 1.049 \times \%RSD) \quad (\text{Equation 3})$$

where:

- %R<sub>L</sub> = low percent recovery limit specified in Table 2, column 5 or 6, as appropriate
- %R<sub>U</sub> = upper percent recovery limit specified in Table 2, column 5 or 6, as appropriate
- $\bar{x}$  = replicate set average (sample mean), defined in Equation 2
- $\mu_0$  = actual known PDP sample value

The measurement will pass the bias acceptance criterion if Equation 3 is satisfied and will fail if Equation 3 is not satisfied.

Equation 3 requires that

$$1.049 \times \%RSD \leq |100\% - \%R_{L,U}| \quad 1.049 \times \%RSD \leq |100 - \%R_{L,H}| \quad (\text{Equation 4})$$

Otherwise, the test will fail. Appendix E provides a detailed discussion of the statistical bases for the precision and bias scoring criteria.

*Actions:* If any measurement system produces results that do not satisfy the appropriate acceptance criterion for bias, that NDA system will be scored as failed for that sample. The impact of failing an acceptance criterion is given in Section 6.3. In accordance with Section 7, the site project manager is responsible for ensuring that appropriate corrective actions are taken, if deemed necessary, initially by the facility measurement organization or subsequently by CBFO.

### **6.3 Use of NDA PDP Test Performance to Support WIPP Qualification**

The primary purpose of the NDA PDP is to independently acquire data from participating NDA measurement systems for the evaluation of the system and facility measurement organizations' capability to produce data that meet the quality requirements for the WIPP, and to reveal any technical or quality assurance-related deficiencies that may negatively impact the characterization of WIPP wastes. Through NDA PDP evaluations, information is gathered on: system performance; NDA measurement organization management quality processes; NDA procedural adequacy, effectiveness and implementation; corrective action effectiveness; and, overall data quality assurance. Finally, the NDA PDP functions to provide technical justification to CBFO for approving (conditionally or without condition) or disapproving NDA systems, procedures, and organizations for making qualified WIPP waste NDA measurements.

The procedures and measurement system parameters used to analyze NDA PDP samples are to be the same as those used in the analysis of WIPP wastes where possible. Due to the fact that NDA PDP samples are analyzed six separate times (unlike WIPP waste samples), the procedure for conducting these replicates will be unique to the NDA PDP. Because count time determinations for NDA PDP samples are directly related to the precision of the results and are scored against NDA PDP criteria, the NDA PDP sample count times must have a direct, procedural correlation with count time determinations for WIPP waste samples.

The CBFO determines the approval status of a measurement organization's NDA measurement capability for any individual NDA system based on passing or failing the NDA PDP scoring criteria. A passing or failing score for a given criterion of the NDA PDP is related to the characteristics of the PDP sample(s) analyzed and is therefore subject to evaluation based upon all of the following specifics of the test: 1) the NDA system; 2) the sample matrix; 3) the activity type; 4) the activity range; and 5) the particular scored parameter (bias or precision). Thus, a pass or fail in the NDA PDP has specific, though potentially broad technical and programmatic ramifications.

Obtaining a passing score on all criteria for all samples presented to an NDA system within an NDA PDP cycle provides CBFO with the evidence and justification for not imposing any restrictions upon WIPP measurements made by that NDA system during the approval period. (Any former restrictions that have not been addressed through CBFO-approved corrective action, recalibration, etc., would continue as restrictions upon the system through the subject cycle approval period.) Approval is based upon the use of the measurement organization's CBFO-approved procedures for samples that exhibit characteristics within the approved system's various parameter calibration ranges.

A failure of an NDA system to meet any of the scoring criteria, however, may require the need for further investigation of the cause of that failure. It is the responsibility of the affected measurement organizations, with assistance and oversight by the NDA PDP Coordinator and other CBFO QA and technical support staff, to establish the most likely causes for their failure of an NDA PDP scoring criterion. Once the causes are reviewed and concurred upon by CBFO, the causes of failure must be evaluated for their potential effect upon WIPP waste analyses. It is incumbent upon the participating measurement organization to demonstrate through technical

justification the impact that an NDA PDP criterion failure has on WIPP waste measurements. CBFO is the final authority on establishing this impact determination.

If the measurement organization can demonstrate that the causes of an NDA PDP criterion failure have no impact on routine WIPP waste analyses, no restrictions will be placed upon the system. Based upon the causes of the failure, CBFO may determine that multiple systems within the organization should be restricted. Restrictions may include disapproval of all measurements made by the system(s) or may be conditional approval restricting measurements for WIPP to certain waste types. As specified in Section 7.1, CBFO will provide a written approval status notification memorandum documenting the approval, disapproval, or conditional approval. The approval status memorandum will provide the basis for the disapproval or conditional approval. Additionally, for conditional approvals, the approval status memorandum will specify the restrictions. If a question arises regarding the appropriate interpretation of an approval status memorandum, a revision to the existing memorandum, or an additional clarifying memorandum, may be issued by CBFO.

If a system has been conditionally approved or disapproved, the measurement organization may choose to take one of the following courses of action:

- Accept the conditional approval or disapproval with no further action (NOTE: accepting disapproval will require the measurement organization to halt the use of the system for performing qualified NDA measurements on WIPP waste until the system can be approved or conditionally approved. Likewise, accepting conditional approval limits the system to making qualified WIPP measurements only on samples meeting the specified conditions of the approval);
- Challenge the conditional approval or disapproval with additional data and other technical justifications for a change in the CBFO approval status;
- Initiate corrective action to eliminate the causes for the condition adverse to quality that resulted in the NDA PDP criterion failure.

If the measurement organization chooses to initiate corrective actions, the measurement organization should:

1. Identify the basis of the failure that addresses all contributing components, technical and/or administrative, and submit them in a corrective action plan (CAP).
2. Submit a CAP to the CBFO for review and approval.
3. Implement the CBFO-approved CAP and provide evidence that the plan effectively addresses the deficiency and the actions are completed.
4. Obtain final CBFO approval, conditional or otherwise, to process WIPP wastes after completion of the CAP.

CBFO or the measurement organization may require analysis or additional measurements of NDA PDP test samples as part of the verification that the corrective actions are effective.

If the CBFO determines that the measurement organization is not responsive or is not adequately addressing a condition adverse to quality that has been determined through its participation in the NDA PDP, the CBFO may formally request a corrective action through CBFO protocol.

## **7.0 APPROVALS AND REPORTS**

### **7.1 Approval Status Notification**

The CBFO, with the assistance of the NDA PDP Coordinator, will evaluate individual facility measurement organization and system performance and approve individual measurement systems for participation in the WIPP waste characterization program in accordance with Section 6.3. At any point in the evaluation process, the CBFO may request additional information from, or hold discussions with, participants regarding systems and procedures used to perform calibrations, performance-check samples, test NDA PDP samples, and test actual wastes. As a result of the NDA PDP performance and related evaluations, the CBFO may issue unqualified approvals, disapprove a method, issue conditional approvals limited to specific activity, waste weight ranges or waste types, or issue conditional approvals based upon other required actions.

The measurement facility organization's managers shall be responsible for ensuring that appropriate corrective actions are taken and that all conditions and limits on approvals are addressed to the satisfaction of the CBFO. The CBFO will issue individual site approval status notification memorandums regarding overall approval, and any specific restricting conditions, of the NDA system(s) for each facility measurement organization. This CBFO memo will specify the approved procedures associated with each NDA system and the period for which each system will maintain its approval status.

### **7.2 Scoring Report**

The NDA PDP Coordinator shall review, evaluate, and score the reported data results for all facility measurement organizations and participating NDA systems, compile them into a scoring report, and deliver this report to the CBFO within four weeks after the sites' final data are received, including receipt of revised data as a result of corrective actions. The report shall include the values reported by the measurement facilities, the reference activity values, the acceptance ranges, and the pass-fail status of each individual measurement system, in addition to CBFO approval status of each participating NDA system.

### **7.3 Distribution of Reports**

#### **7.3.1 Approval Status Notification Memoranda**

CBFO approval status notification memoranda are sent to the corresponding DOE Operations Office involved, the participant measurement organization, and other relevant stakeholders as deemed appropriate by CBFO.

#### **7.3.2 Scoring Report**

Copies of the scoring report are distributed to each of the DOE Operations Offices involved in the NDA PDP cycle being reported, each of the participating measurement organizations, and other individuals and organizations deemed appropriate by the CBFO. The CBFO shall also provide written notification to the DOE Operations Offices regarding the adequacy and approval status of their participating measurement organization's NDA systems and procedures. Distribution will be in an electronic format unless the recipient requests a hardcopy report.



## 7.4 Facility Measurement Organization and NDA System Status

Once the CBFO has determined an organization's measurement systems and methods status as "approved" or "conditionally approved," such status shall remain in effect for a maximum of 13 months (12 months plus a one-month "grace" period). All measurement systems must participate in the subsequent annual primary cycle in order to remain qualified to perform WIPP analyses. Measurement systems obtaining approval status through a supplemental cycle must participate in the next regular primary cycle for reevaluation of their approval status. This participation could change the approval status of a system and will reset the 13-month approval period as stated below.

The approval period for a measurement system begins with the date that signed data reports from an NDA PDP cycle are received by the NDA PDP Coordinator. At the end of the 13th month, a system that has not yet successfully completed the analyses of NDA PDP samples to requalify may choose to proceed at risk with WIPP analyses, or to cease operations. The organization should recognize that data obtained at risk may be found to be unacceptable to WIPP. Data generated at risk cannot be used for characterizing waste for shipment to WIPP until:

- The system and methods used to collect and process the data satisfy the CBFO through successful NDA PDP sample measurement performance, and
- The data obtained during the "at risk" period have been reconciled through the disposition of a nonconformance report.

## 8.0 QA RECORDS

The minimum QA records for the NDA PDP are identified and listed below in accordance with the QAPD requirements. In addition, the NDA PDP Coordinator may determine that records of other program activities are QA records and enter them into the QA records system with the same level of control and maintenance.

These QA records may be organized by NDA PDP Plan revision, by NDA PDP cycle, or other principle, as applicable. These records are nonpermanent records and shall be maintained in accordance with the QAPD requirements. Records disposition, when applicable, will be in accordance with CBFO/NTP requirements, approved procedures, and work plans.

All QA records identified in this plan shall be stored in accordance with records storage requirements in the QAPD. Access to QA records will be limited to personnel involved in the program or having related QA or records custodial responsibilities.

The following documents will be maintained as QA records for the NDA PDP:

- PDP plans (all revisions)
- Procurement records
- Radioactive standard and matrix SWB design and production records (each SWB and PDP standard production phase)
- SPT training (training materials and attendance records)
- Assay system registration forms
- Records of cycle set-up (notification letters, shipping records, and other correspondence)
- Participant assay reports and supporting forms (assay data report forms, chain-of-custody records, and configuration forms)
- Scoring reports
- Reviews of corrective actions and supporting data and recommendations made to CBFO

The following matrix of QA records provides a more detailed listing of records and designates responsibility for maintenance.

### NDA PDP Documentation/Records List

Document(s)	QA Record	Storage Location	Comments
1. PDP Plan revisions	Yes	CBFO	For each revision.
2. PDP Plan revisions — comments and resolutions	Yes	CBFO	For each revision.
3. SPT training packages	Yes	CTAC	For each revision.
4. Approval from CBFO for schedule and participants	Yes	CBFO	Letter or hard copy of e-mail(s)
5. Participant NDA PDP program documentation - Procedures - Raw data - Calibration records - Training records	Yes	Participant	These should be exactly the same as are maintained/generated in waste characterization activities; required by WAC and PDP Plans.
6. SPT training records - Completion forms	Yes	Participant	Copies to CBFO and CTAC
7. Correspondence to participants providing instructions for execution of an NDA PDP cycle	Yes	CBFO	Copies to CBFO and CTAC.
8. Sample configuration instructions accompanying notification	Yes	CBFO	Developed by the NDA PDP Coordinator. Confidential until completion of cycle.
9. Participant correspondence requesting time extension for submitting results	Yes	CBFO	As required by PDP Plans, e-mails to the NDA PDP Coordinator.
10. Responses to extension requests	Yes	CBFO	Responses issued by CBFO.
11. Participant data packages with cover letters (including any revisions and corrections to data) -Assay data report forms -Chain-of-custody records -Configuration forms -Disassembly forms	Yes	CBFO	Formally transmitted to CBFO on completion of all cycle-specific activities.
12. Scoring report	Yes	CBFO	Formally transmitted to CBFO/CTAC file copy. CBFO approves distribution by the NDA PDP Coordinator.
13. Records of QA review of scoring report	Yes	CBFO	Formally transmitted to CBFO/CTAC file copy.

<b>Document(s)</b>	<b>QA Record</b>	<b>Storage Location</b>	<b>Comments</b>
14. Memoranda issued by CBFO to provide status notification to participants	Yes	CBFO	CTAC maintains a file copy.
15. Transmittal letter with cycle specific records	Yes	CBFO	Transmitted upon completion and receipt of all cycle records. .
16. Current document, software revision list, and software verification and validation documentation	Yes	CBFO	Required by the CBFO QAPD.
17. NDA PDP MP	Yes	CTAC	CBFO reviews to ensure MP meets CBFO requirements.
18. Participants' reports of corrective actions	Yes	CBFO	Submitted to CBFO.

## 9.0 GLOSSARY

**ACTIVE SYSTEM** – An operational NDA system currently located at a participant site and qualified to perform waste characterization activities at that site. This includes systems that are not actively assaying waste because of scheduling issues or other site issues not connected to system capability or readiness.

**ASSAY COORDINATOR** – Facility contact responsible for accepting NDA PDP samples and ensuring that chain-of-custody protocols are followed. This individual acts as a measurement organization's primary point of contact for receipt and appropriate dissemination of communication from the NDA PDP Coordinator.

**BIAS** – The systematic error component of the total uncertainty, that is, a constant positive or negative deviation of the method average from the correct value or an accepted reference value under specific measurement conditions. Bias is represented in NDA PDP summary reports as percent recovery (%R).

**CORRECTIVE ACTION** – Measures taken to rectify conditions adverse to quality and, where necessary, to preclude their recurrence.

**INACTIVE SYSTEM** – A CBFO-approved and operational NDA system not being used to characterize WIPP wastes for the NTP at the time a primary NDA PDP cycle is conducted.

**MEASUREMENT ORGANIZATION** – The entity responsible for the assay of NDA PDP samples and WIPP waste. Frequently this entity is not the same company or entity that functions as the site facility contractor.

**MEASUREMENT SYSTEM** – The individual NDA instrument that has received a unique NDA PDP registration number. A measurement system may function with various independent modes of assay.

**NDA PDP COORDINATOR** – An individual responsible for coordinating the technical operations of the NDA PDP, including designation of NDA PDP cycle-specific sample component configuration, procurement of materials and services required for replacement and/or manufacture of new NDA PDP sample components (i.e., NDA PDP SWBs, matrix modules and other consumables), SPT oversight, scheduling NDA PDP cycles, scoring NDA PDP data received from participants, summary report generation, and preparation of other NDA PDP-related CBFO documents as directed and for approval by the CBFO PDP Appointee.

**NDA PDP SAMPLE** – A blind sample prepared and sealed by the SPT for subsequent analysis by a measurement system for qualification under the PDP. A PDP sample for the box NDA PDP is comprised of an SWB configuration box with matrix modules and PDP standards installed in accordance with instructions received from the NDA PDP coordinator. Sample matrix and source characteristics will (depending on availability of NDA PDP SWB matrix modules) representatively span nominal WIPP waste characteristics expected to be received for characterization by the measurement organization including, but not be limited to, isotopics, plutonium concentration, ( $\alpha,n$ ) reactions, interfering matrices, and source distribution.

**NDA PDP STANDARD** – A radioactive source specifically designed, prepared, or acquired and certified for the NDA PDP.

**NDA PDP STANDARDS CUSTODIAN** – The lead member of the SPT responsible for coordination of on-site NDA PDP sample preparation activities.

**NONDESTRUCTIVE ASSAY** – Assay methods for waste items that do not affect the physical or chemical form of the material.

**NON-INTERFERING MATRIX** – Specifies an SWB box sample that contains only the supports for the PDP standards, i.e., no installed matrix modules, and serves as the non-interfering matrix test sample.

**PDP MANAGER** – An individual within the Program Coordinator organization responsible for overall performance of the NDA PDP and other elements of the PDP (Headspace Gas and RCRA Constituent Analysis of Solidified Wastes).

**PROGRAM COORDINATOR** – A CBFO-designated organization that administers and coordinates PDP functions. The program coordinator will designate the PDP Manager.

**PDP STANDARDS CONFIGURATION ATTESTANT** – A member of the two-person SPT responsible for verifying the proper configuration of the NDA PDP sample, including emplacement of NDA PDP standards and matrix module array and performing sample security-related procedures.

**PRECISION** – A measure of the variance among individual measurements of the same property made under prescribed conditions. Precision is represented in NDA PDP summary reports as a percent relative standard deviation (%RSD).

**PRIMARY CYCLE** – The annual NDA PDP cycle. The primary cycle is included in the Program Coordinator's master project schedules for the NDA PDP and occurs at approximately the same time each year to ensure a site receives the opportunity to gain NDA PDP approval every 12 months.

**PROGRAM COORDINATOR** – A CBFO-designated organization that administers and coordinates PDP functions. The program coordinator will designate the PDP manager.

**SAMPLE PREPARATION PROCEDURE** – A procedure generated by the NDA PDP Coordinator for each facility measurement organization for each NDA PDP cycle. This procedure provides instructions to the SPT on configuration of the NDA PDP sample (i.e., emplacement of NDA PDP standards and matrix module array within a specified configuration NDA PDP SWB).

**SAMPLE PREPARATION TEAM (SPT)** – A two-person team, consisting of an NDA PDP standards custodian and PDP standards configuration attestant that prepare and certify NDA PDP samples for a given facility measurement organization. The SPT is responsible for ensuring that each NDA PDP sample is prepared according to the NDA PDP sample preparation procedures provided by the NDA PDP Coordinator. In addition, the SPT ensures proper disassembly and

return to storage of all NDA PDP components after analysis by the facility measurement organization.

**SUPPLEMENTAL CYCLE** – An NDA PDP cycle in addition to the annual primary NDA PDP cycle. Reasons that a supplemental cycle may be necessary include accommodation of measurement facilities unable to participate in the primary cycle, to support implementation of new or modified systems, or to perform specific testing as directed by the CBFO. Additional supplemental cycles may be conducted on an as-needed basis at CBFO direction.

**SWB CONFIGURATION BOX** – A specially modified SWB that contains a floor reinforcement structure that also serves to align and secure installed matrix modules and NDA PDP standards. The configuration box is used to assemble the SWB NDA PDP sample in accordance with instructions provided by the NDA PDP Coordinator.

**SWB MATRIX MODULE** – A matrix module is used to configure a waste matrix array within the configuration SWB. A total of 60 modules are needed to completely fill an SWB, but the configuration box can be configured with a lesser number to produce void spaces and heterogeneous matrix distributions. Of the 60 modules, 48 are center type modules and 12 are curved end modules. The dimensions of the two different types of modules are designed to accommodate the physical design of the SWB box.

**SWB STORAGE BOX** – An SWB with internal structure to house and protect a matrix module set. The storage box can also be used for transportation of the modules, provided the modules contained within are properly packaged.

**TOTAL MEASUREMENT UNCERTAINTY** – The propagated measurement error potential from all bias and precision sources including interference effects such as variable matrices, isotopic compositions, spatial distributions, contaminating radionuclides, and others.

## 10.0 REFERENCES

- CBFO-94-1012, *Quality Assurance Program Document*, current revision, U.S. Department of Energy Carlsbad Field Office, Carlsbad, New Mexico.
- DOE/CAO-95-1121, *Transuranic Waste Baseline Inventory Report*, current revision, U.S. Department of Energy Carlsbad Field Office, Carlsbad, New Mexico.
- DOE/WIPP-02-3122, *Transuranic Waste Acceptance Criteria for the Waste Isolation Pilot Plant*, current revision, Waste Isolation Pilot Plant, U.S. Department of Energy, Carlsbad, New Mexico.
- DOE/CBFO-01-1005, *Performance Demonstration Program Plan for Nondestructive Assay of Drummed Wastes for the TRU Waste Characterization Program*, current revision, U.S. Department of Energy Carlsbad Field Office, Carlsbad, New Mexico.
- DOE/CBFO-01-3107, *Performance Demonstration Program Management Plan*, current revision, U.S. Department of Energy Carlsbad Field Office, Carlsbad, New Mexico.
- INEEL/EXT-02-01271, *Nondestructive Assay Performance Demonstration Program: Standard Waste Box, Dry Combustibles Waste Matrix Surrogate-Specification, Design, and As-Built Material Properties for NDA PDP-SWB-01*, September 2002, Idaho National Engineering and Environmental Laboratory, Bechtel BWXT Idaho, LLC.
- INEEL/EXT-02-01272, *Nondestructive Assay Performance Demonstration Program: Standard Waste Box, Dry Combustibles Waste Matrix Surrogate-Specification, Design, and As-Built Material Properties for NDA PDP-SWB-02*, September 2002, Idaho National Engineering and Environmental Laboratory, Bechtel BWXT Idaho, LLC.
- INEEL/EXT-02-01273, *Nondestructive Assay Performance Demonstration Program: Standard Waste Box, Mixed Metals Waste Matrix Surrogate-Specification, Design, and As-Built Material Properties for NDA PDP-SWB-03*, September 2002, Idaho National Engineering and Environmental Laboratory, Bechtel BWXT Idaho, LLC.
- INEEL/EXT-02-01274, *Nondestructive Assay Performance Demonstration Program: Standard Waste Box, Mixed Metals Waste Matrix Surrogate-Specification, Design, and As-Built Material Properties for NDA PDP-SWB-04*, September 2002, Idaho National Engineering and Environmental Laboratory, Bechtel BWXT Idaho, LLC.
- INEEL/EXT-03-00535, *Nondestructive Assay Performance Demonstration Program: Standard Waste Box, Concrete Debris Waste Matrix Surrogate-Specification, Design, and As-Built Material Properties for NDA PDP-SWB-05*, September 2003, Idaho National Engineering and Environmental Laboratory, Bechtel BWXT Idaho, LLC.
- INEL-94/0104, *Performance Demonstration Program for Nondestructive Assay for the TRU Waste Characterization Program, Initial Cycle Source Design*, Idaho National Engineering and Environmental Laboratory, Lockheed Martin Idaho Technologies Company, LLC
- LA-CP-00-54, *National Transuranic Waste Program Nondestructive Assay Performance Demonstration Program Enriched Uranium Production Plan – Phase II.C*, current revision, Los Alamos National Laboratory, Los Alamos, New Mexico.



LA-CP-00-110, *National TRU Waste Program NDA PDP Depleted Uranium Production Plan – Phase II.D*, current revision, Los Alamos National Laboratory, Los Alamos, New Mexico.

LA-CP-01-208, *National TRU Waste Program Non-Destructive Assay Performance Demonstration Program Large Particle Working Reference Material Production Plan – Phase II.B*, current revision, Los Alamos National Laboratory, Los Alamos, New Mexico.

LA-CP-03-0072, *National TRU Waste Program Non-Destructive Assay Performance Demonstration Program Increased Americium: Plutonium Working Reference Material Production Plan – Phase III.A*, current revision, Los Alamos National Laboratory, Los Alamos, New Mexico.

LA-CP-03-0763, *National TRU Waste Program Non-Destructive Assay Performance Demonstration Program Heat Source Plutonium Working Reference Material Production Plan – Phase III.B*, current revision, Los Alamos National Laboratory, Los Alamos, New Mexico.

LAUR-96-2277, *NDA PDP Working Reference Material Productions Plan – Phase I*, current revision, Los Alamos National Laboratory, Los Alamos, New Mexico.

LAUR-98-213, CST-8-PLA-STD-106, *NDA PDP High Mass Working Reference Material Production Plan – Phase II.A*, current revision, Los Alamos National Laboratory, Los Alamos, New Mexico.

## **Appendix A**

### **NDA Box PDP Registration Form**

## **Appendix A NDA Box PDP System Registration Form**

### **General Instructions**

1. Registration forms are to be completed and returned to the NDA PDP Coordinator at least three (3) weeks prior to initial participation in the PDP.
2. Separate registration is required for each NDA measurement system.
3. After initial submission, the forms need be resubmitted only when a change is made in the registration information.
4. The NDA PDP Coordinator will acknowledge all registration requests and assign a tracking identifier to each registered system.
5. The NDA PDP Coordinator will maintain a current list of all registered systems.

### **Instructions for Specific Questions**

#### Section A

1. Enter the full formal name of the measurement system.
2. Enter the acronym by which the system should be referenced.
3. Enter a number associated with this unit (if applicable).
4. Check the appropriate descriptor. "Fixed, Permanent" indicates that the system was intended to be installed permanently at the current location. "Transportable, Nonpermanent" indicates a long-term installation that can be relocated. "Mobile, Trailer" indicates systems intended for routine movement between sites for short-term contracts.
5. Enter the DOE site where the system will be installed for NDA PDP cycle participation.
6. Enter the on-site location designator for the system.
7. Enter the name of the institution/facility/company that owns the system.
8. Enter the name of the institution/facility/company that operates the system.
9. Enter the name of the person who should be contacted for information on the system.
10. Enter the title of the person identified in box 9.
11. Enter the affiliation of the person identified in box 9.
12. Enter the mailing address for the person identified in box 9.
13. Enter the express package delivery address (i.e., street address, not a P.O. address) for the person identified in box 9.
14. Enter the e-mail address for the person identified in box 9.
15. Enter the phone number for the person identified in box 9.
16. Enter the fax number for the person identified in box 9.

### Section B

1. Enter a description of the system, its principles of operation, and optional modes for assay.
2. Enter the identifier(s) for the written standard operating procedures (SOPs) that are used to operate the system for waste assay.
3. For each measurement mode of the system that may be used, enter the measurement principle (gamma, neutron), mode identification (active neutron, etc.), the procedure documenting selection criteria for selecting the subject modes, and the source of isotopic data used for that mode. Sources of isotopic data may be coded:
  - P = isotopic data are measured as an integral part of the primary quantitative assay (e.g., gamma spectrometric methods used for both the quantitative and isotopic data).
  - S = isotopic data are derived from a secondary method (e.g., the primary quantitation is by passive neutron assay, but isotopic ratios are obtained from an independent gamma spectrometric method).
  - AK = isotopic data are obtained from acceptable knowledge of the waste stream or container.

### Section C

- 1 through 5. Check off Yes or No to each question. For each “Yes,” indicate the applicable mode(s) from section B.3.
6. Enter the possible mode(s) from section B.3 for each combination of activity range and waste type. Enter “NA” for combinations for which the system will not be used. If explanatory information is required, enter a number in the comments column and add the number and explanation to section D. For example, a system may have a calibration cut-off that falls at the midpoint of a test range. This may be indicated by accepting the range, but specifying a numerical limit in the comment.
- 7 through 9. Enter the values and units for any limits on NDA PDP tests that, if exceeded, would prevent the system from assaying an NDA PDP sample.

### Section D

Add any comments necessary to explain answers in any prior sections or supplemental information useful to the NDA PDP Coordinator in planning effective NDA PDP tests for the system. Attach continuation sheets as needed.

### Section E

Enter the requested information for the person submitting the registration form.  
Sign and forward the original of the form to the NDA PDP Coordinator.

### Performance Demonstration Program for the Box NDA PDP System Registration Form

<b>A. SYSTEM IDENTIFICATION</b>				
1. Official System Name:				
2. Acronym		Coordinator Use Only		
		System ID:		
3. Unit No. (this system):		Group No.:		
4. Mobility Type:	Fixed, Permanent <input type="checkbox"/> Transportable, Nonpermanent <input type="checkbox"/> Mobile, Trailer <input type="checkbox"/>			
5. Current Facility Location:		6. On-Site Reference		
7. System Owner:				
8. System Operator:				
9. Primary Contact Name:		14. E-Mail:		
10. Title:		15. Phone:		
11. Affiliation:		16. Fax:		
12. Postal Address:				
13. Express Package Address:				
<b>B. METHOD SUMMARY</b>				
1. Brief Description of Method:				
2. Associated SOP Identification(s):				
3. For each quantitative mode in which the system is used, complete the following:				
	3a. Assay Measurement Basis	3b. Mode	3c. Criteria for Selection	3d. Source of Isotopic Data
Quantitative Mode 1				
Quantitative Mode 2				
Quantitative Mode 3				
Quantitative Mode 4				

<b>C. SCOPE AND LIMITATIONS ON SYSTEM USE</b>						
				YES	NO	If YES, Mode No(s):
1. Will the system be used to certify waste as TRU, for SWBs containing less than 0.01 curies of TRU isotopes?						
2. Will the system be used for wastes containing weapons grade plutonium?						
3. Will the system be used for wastes containing heat source plutonium?						
4. Will the system be used for wastes containing unknown isotopic ratios?						
5. Will the system be used for wastes containing uranium isotopes?						
6. Indicate the ranges and waste types (with similar nuclear interaction characteristics) for which the system intends participation in the NDA PDP. For systems with multiple quantitative modes, be sure to indicate the applicable mode(s) for each case.						
Activity range	Range in alpha-curies <sup>a</sup>	Combustibles		Metals	Concrete	Comment No.
Low	> 0 to 0.02					
Mid-Low	> 0.02 to 0.2					
Mid-High	> 0.2 to 2.0					
High	> 2.0					
a. Range of TRU activity in an SWB; units are curies of alpha-emitting TRU isotopes with half-lives greater than 20 years.						
7. Indicate the maximum activity permissible (including units) for testing the system due to calibration, radiological safety, or administrative limits:				Value:	Units:	
8. Indicate the maximum weight permissible (including units) for testing the system due to calibration, safety, or administrative limits:				Value:	Units:	
9. Indicate any other limitations on system tests: (Explanation in Comment No. _____.)				Value:	Units:	
<b>D. COMMENTS (Please add any information relative to participation of this system in the NDA Box PDP)</b>						
<b>E. Please register the system described in this application for participation in future cycles of the NDA Box PDP. It is understood that system tracking, test design, approval conditions, participation requirements, and audit follow-up may be based on the information supplied in this application.</b>						
Printed Name:			Signature:			Date:
Phone Number:			E-Mail:			
<b>F. DISPOSITION (coordinator use only)</b>						

## **Appendix B**

### **NDA PDP Standard Encapsulation Design**

## **Appendix B**

### **NDA PDP Standard Encapsulation Design**

This appendix provides information on the NDA PDP standard encapsulation design used to contain the radioactive material/substrate mixture that constitutes a standard. Seven separate NDA PDP standard production phases were conducted at the Los Alamos National Laboratory. Each production phase was designed to yield a set of standards with specific attributes reflecting the DOE radioactive material inventory. All NDA PDP standards use a dual cylinder encapsulation design and have identical internal and external dimensions. The encapsulation cylinders are fabricated from seamless stainless steel tubing for all production phases except Phase III.A, which is fabricated from seamless zirconium tubing.

The PDP standard encapsulation is comprised of an inner and outer cylinder. The bottom end cap of each cylinder is laser-welded in place. The inner cylinder is then filled with the appropriate mixture of radioactive material and substrate. Once the mixture has been packed to a height specified in the production plan document (LAUR-96-2277, LAUR-98-213, LA-CP-00-54, LA-CP-00-110, LA-CP-01-208, LA-CP-03-0072, LA-CP-03-0763), a graphite-felt frit is installed, which presses the nuclear material/substrate assembly in place when the top cap is inserted and attached. The graphite frit also ensures that the radioactive material/substrate configuration does not change over time. The inner cylinder top cap is then welded in place using the tungsten inert gas (TIG) method. After the top cap is welded in place, the inner cylinder is inserted into the outer cylinder and the top outer cylinder cap is TIG-welded in place. An elevation view of both the inner and outer encapsulation cylinders is shown in Figure B-1. The final assembled NDA PDP standard encapsulation unit is shown in Figure B-2. Prepared assemblies of the stainless steel and zirconium dual encapsulation, complete with the substrate matrix (no radioactive material) and helium fill, have been tested in accordance with ANSI/HPS N43.6-1997 and comply with ANSI Classification 97C43323.

The dimensional and material properties of the NDA PDP standard were derived as a function of NDA PDP objectives, nondestructive waste assay system response characteristics, and practicalities of fabrication. A complete NDA PDP standard specification with supporting analyses is provided in the document, *Performance Demonstration Program for Nondestructive Assay for the TRU Waste Characterization Program, Initial Cycle Source Design* (INEL-94/0104).

The as-specified PDP standard configuration complies with the following general requirements:

1. PDP standards must be physically stable and invariant with time in a defined geometry.
2. The PDP standard configuration must facilitate convenient loading of the standards into the PDP matrix drum or SWB.
3. The PDP standard dimensions must allow for the production of multiple-source spatial geometries within the PDP matrix drum or SWB.
4. The PDP standard encapsulation integrity must comply with all applicable standards and be acceptable for transportation to and storage at participating sites.
5. The PDP standard design must accommodate available fabrication technologies at a reasonable cost.



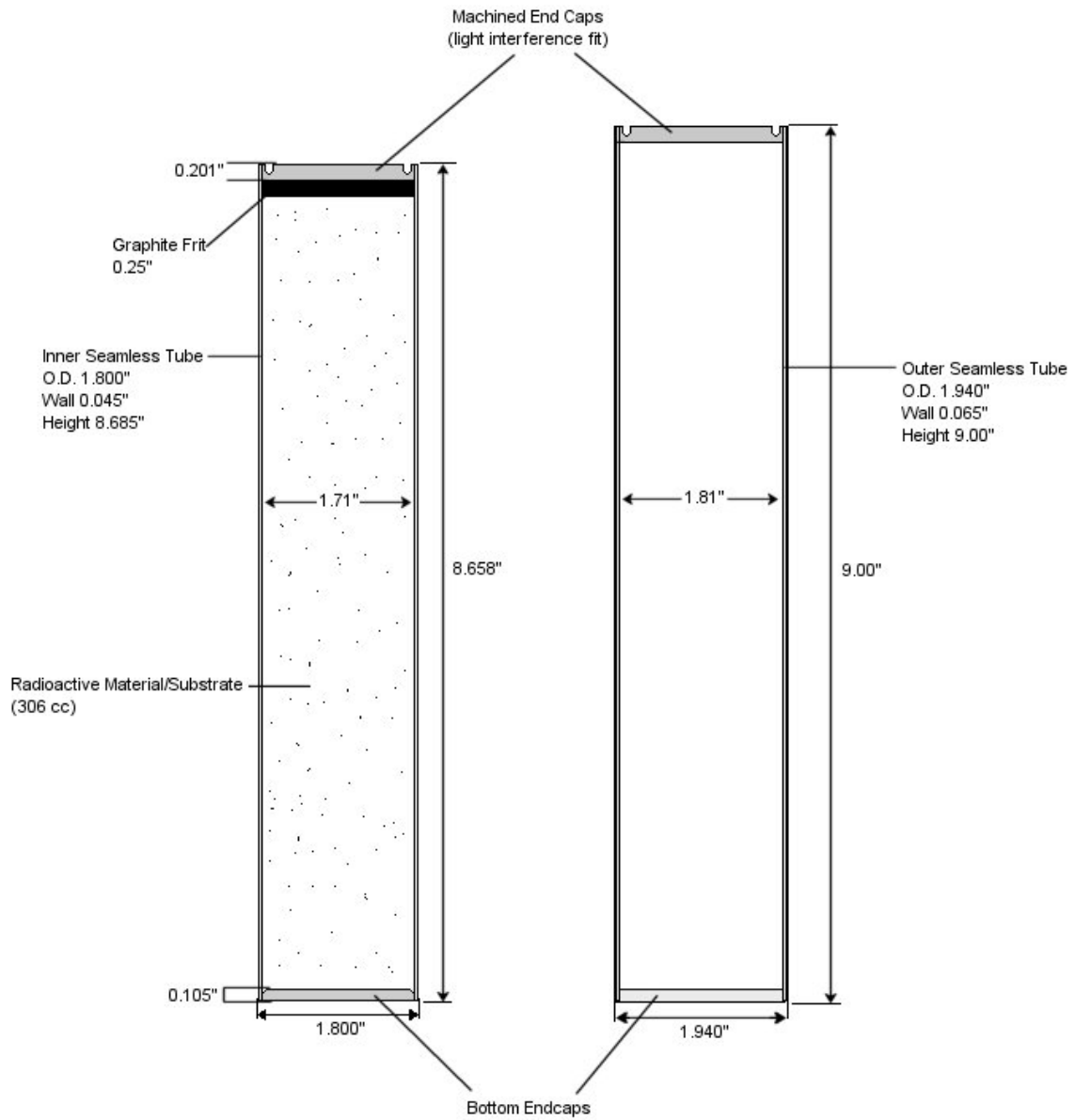

Figure B-1. PDP standard inner and outer cylinders, elevation view.

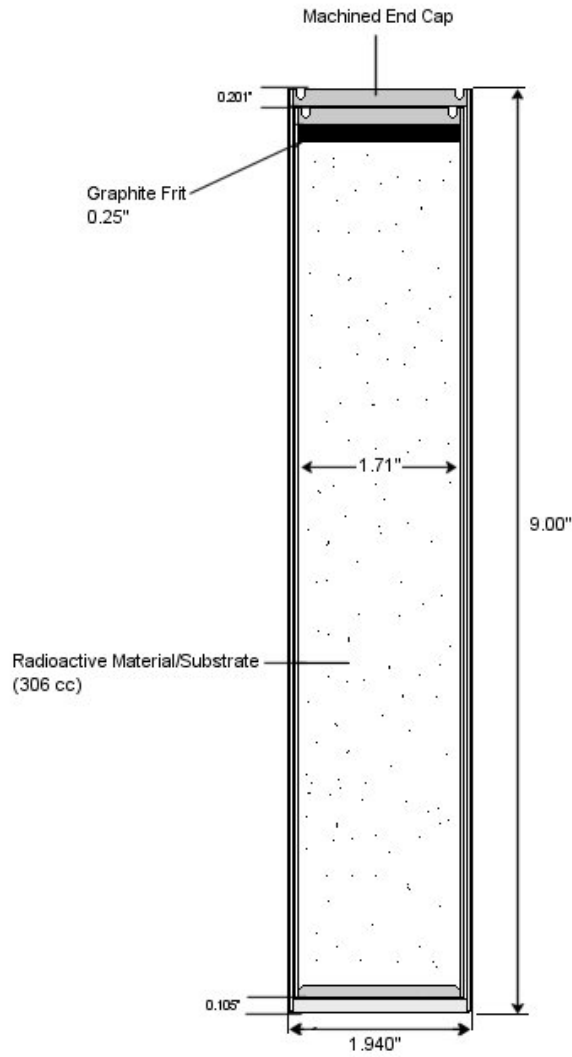

Figure B-2. PDP standard encapsulation assembly, elevation view.

## **Appendix C**

### **SWB Matrix Box Specifications and Descriptions**

## **Appendix C**

### **SWB Matrix Box Specifications and Descriptions**

This appendix provides an overview of the NDA PDP SWB matrix box set, general specifications, designs, and physical configurations. Additional technical detail on the design and fabrication of the NDA PDP SWB matrix box set is provided in the following documents:

1. *Nondestructive Assay Performance Demonstration Program: Standard Waste Box, Dry Combustibles Waste Matrix Surrogate-Specification, Design, and As-Built Material Properties for NDA PDP-SWB-01, INEEL/EXT-02-01271.*
2. *Nondestructive Assay Performance Demonstration Program: Standard Waste Box, Dry Combustibles Waste Matrix Surrogate-Specification, Design, and As-Built Material Properties for NDA PDP-SWB-02, INEEL/EXT-02-01272.*
3. *Nondestructive Assay Performance Demonstration Program: Standard Waste Box, Mixed Metals Waste Matrix Surrogate-Specification, Design, and As-Built Material Properties for NDA PDP-SWB-03, INEEL/EXT-02-01273.*
4. *Nondestructive Assay Performance Demonstration Program: Standard Waste Box, Mixed Metals Waste Matrix Surrogate-Specification, Design, and As-Built Material Properties for NDA PDP-SWB-04, INEEL/EXT-02-01274.*
5. *Nondestructive Assay Performance Demonstration Program: Standard Waste Box, Concrete Debris Waste Matrix Surrogate-Specification, Design, and As-Built Material Properties for NDA PDP-SWB-05, INEEL/EXT-03-00535.*

Use of the waste matrix box surrogate in combination with the NDA PDP standards provides the CBFO with information useful in assessing the ability of DOE facility measurement organizations to meet requirements for NDA of wastes intended for disposal at WIPP. The CBFO uses data generated in the NDA PDP as part of the assessment and approval process for measurement facilities supplying services for the characterization of WIPP TRU waste.

An NDA PDP SWB matrix box must nominally represent the attributes and properties of DOE-generated TRU wastes packaged in the SWB container. The NDA PDP SWB surrogate waste matrix characteristics considered in the specification and design of the NDA PDP SWB include matrix homogeneity, elemental composition, density, and total mass. To support the SWB box assay system performance assessments based on the NDA Box PDP Plan, considerable effort is involved in the specification, definition of requirements, final design, and fabrication of the SWB matrices. The establishment of realistic attributes and design in terms of actual SWB matrix inventories allows CBFO to relate box assay system function and performance to WIPP waste matrix configurations. This allows statements regarding box assay system performance to be referenced to a specific, known, and documented boxed waste form configuration.

Multiple requirements define the design of the NDA PDP SWB waste matrix surrogate. These requirements range from ensuring a faithful replication of the nominal properties of the SWB waste types of interest to construction methods that result in robust long-lasting matrix modules

and precise positioning of radioactive standards. The major matrix surrogate requirements are listed below.

1. Surrogate waste matrix properties must nominally represent specified DOE-generated waste forms as packaged in the SWB container. For the NDA Box PDP, three SWB matrix types have been developed: mixed metals, dry combustibles, and concrete debris. These matrices were developed considering the expected properties of WIPP waste including matrix density, matrix elemental composition, matrix box fill height and geometrical distribution.
2. The matrix surrogate array consists of 60 modules that can be used to construct variations in the physical geometry of the waste matrix ranging from uniform matrix loading to extreme heterogeneous distributions.
3. The surrogate matrix modules must be of manageable size and weight to support routine manual handling of the surrogate box module configuration.
4. The surrogate matrix modules must be robust to withstand transportation and routine handling.
5. The design of the sample configuration SWB must have an internal support structure that provides a convenient means to externally introduce and locate radioactive standards into the interior SWB volume containing matrix modules.
6. The SWB internal support structure must allow for positioning of one or more radioactive standards at various X-Y box coordinates and vertical heights (Z) sufficient to produce radioactivity distributions useful in the assessment of NDA performance.
7. The radioactive standard insertion mechanism must allow for precise and reproducible positioning of NDA PDP standards.
8. The internal support structure design and materials must inherently minimize interferences arising from interaction with the characteristic radiations utilized for waste NDA measurements, be representative constituents, or have nearly equivalent properties of the waste form being simulated.
9. The matrix SWB design must allow consistent reproduction of matrix/standard configurations through time.
10. The matrix surrogate must include design provisions ensuring a stable, non-variable, and effectively inert matrix.
11. The matrix material must comply with health and safety considerations such that the materials are not hazardous, necessitating special handling and storage precautions.
12. The SWB surrogate must be readily differentiable from the actual waste SWBs through a unique color and have a durable exterior alphanumeric identification.

13. A means to address void spaces introduced by surrogate configuration box fixtures must be provided.
14. Matrix modules must be of dimensions allowing interchangeability with matrix modules of different material type composition such as void, metals, or a combustibles type modules.
15. The surrogate configuration shall not manifest systematic effects in commonly employed NDA measurement methods. Rather, the configuration must be random in attribute distribution.

In accordance with the general requirements listed above, the SWB waste matrix surrogate consists of a set of 60 modules that when combined, fill the interior volume of the SWB configuration box to a fill height of approximately 87% (1,538,744 cm<sup>3</sup>) of the interior box height. The multiple module design allows flexibility in configuration of the NDA PDP SWB sample.

The multiple module strategy provides for sample configurations ranging from a uniform matrix distribution throughout the box to a heterogeneous distribution assembled with void modules or modules of differing matrix types. Presently, three NDA PDP SWB matrix types are available: mixed metals, dry combustibles and concrete debris. The ability to mix and match matrix module types allows CBFO to create surrogate matrix configurations that span a range of test sample matrix configurations. An isometric of the SWB multi-module configuration as installed in an NDA PDP SWB configuration box is shown in figure C-1.

Each NDA PDP SWB matrix module set consists of two different module shapes, referred to as the center module and the end type module. The center modules are used in the rectangular midsection of the SWB box and the end modules are used to accommodate the curved ends of the SWB, as shown in figures C-2 and C-3, respectively.

The matrix modules have insert fixture pass-through holes to provide for the insertion and precise positioning of NDA PDP standards within the matrix. The SWB matrix module pass-through holes allow installation of aluminum NDA PDP standard insert fixtures for each of the 24 insert tube locations (figure C-4). If specified for a given matrix module, the NDA PDP standard(s) is positioned at a desired vertical location in the insert fixture through the use of locating pins. The insert fixture is then positioned into the SWB matrix module array. Matrix spacers are provided when appropriate, for use with the matrix surrogate to fill any void space within the insert fixture not occupied by NDA PDP standard(s), thus eliminating undesirable vertical void spaces.

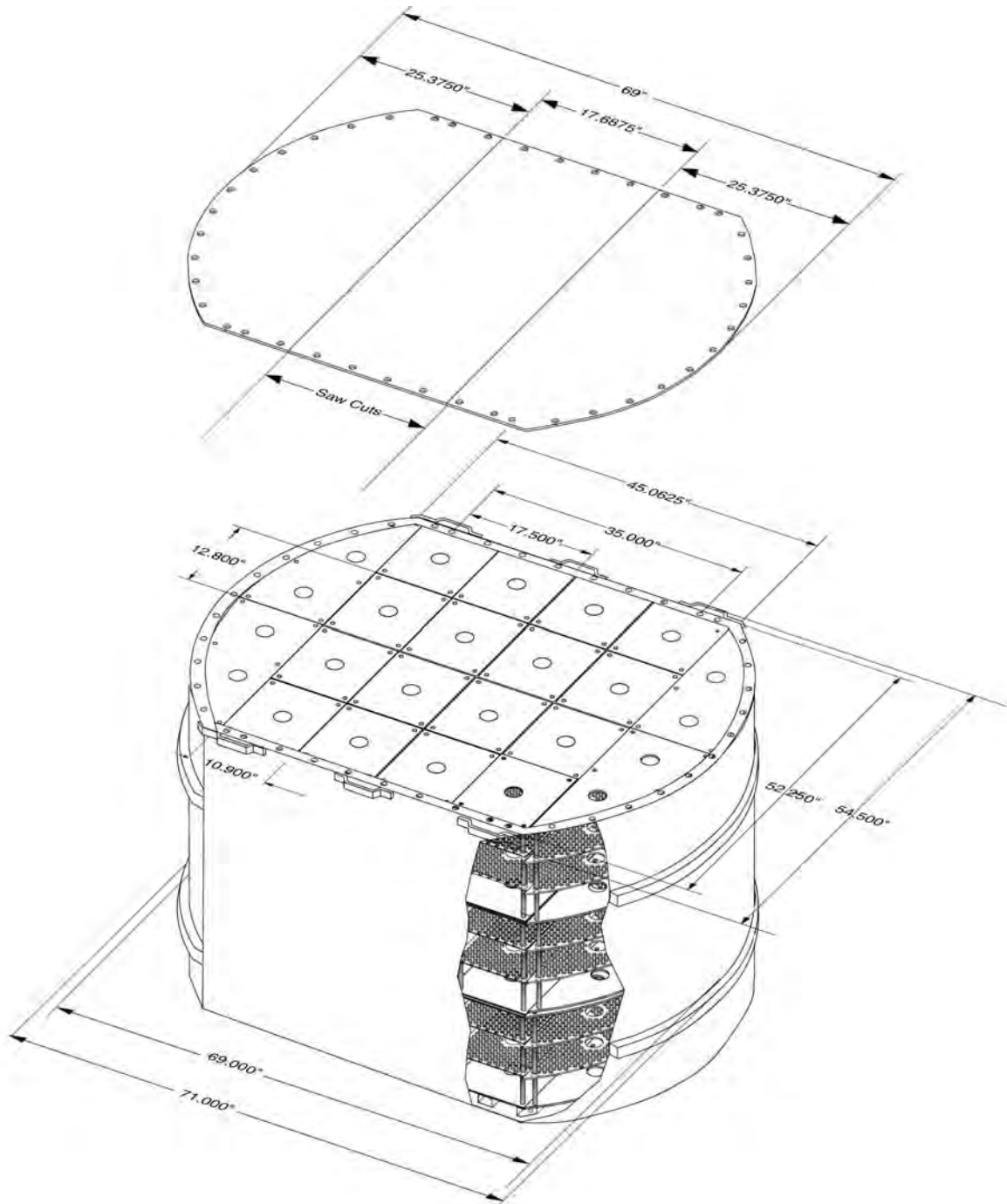

Figure C-1. Cutaway isometric of SWB matrix surrogate.

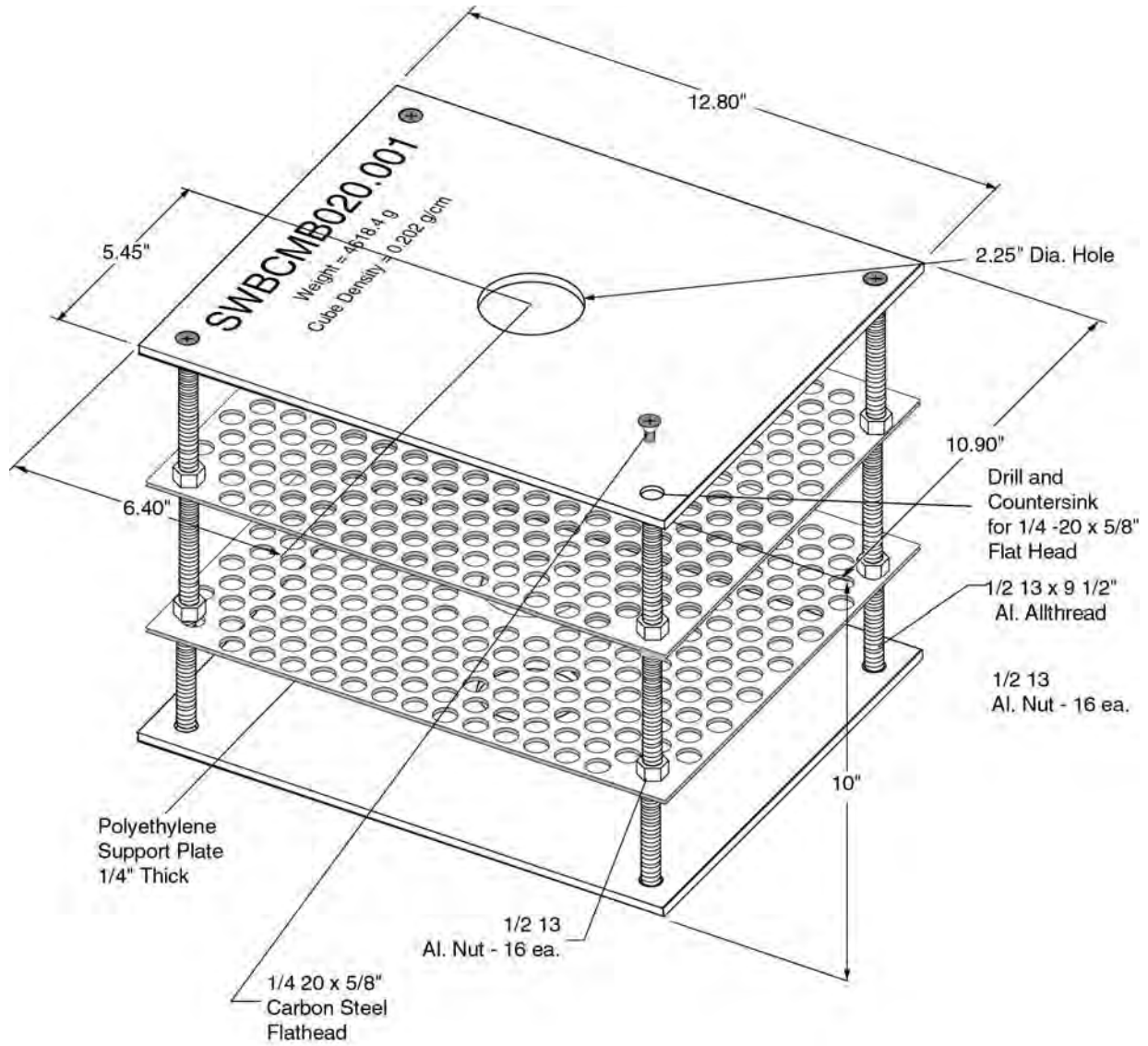

Figure C-2. Center type SWB matrix module.



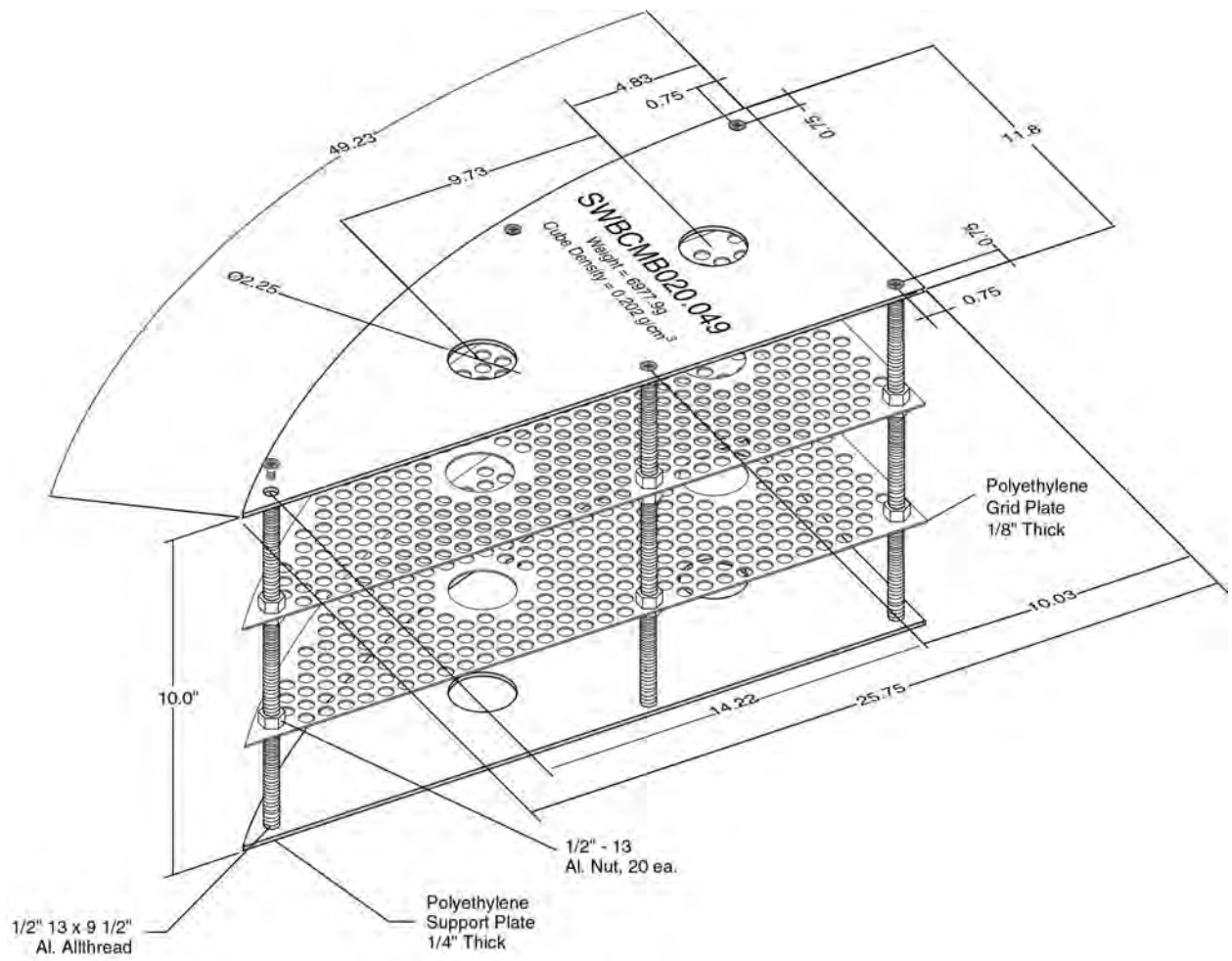

Figure C-3. End type SWB matrix module.

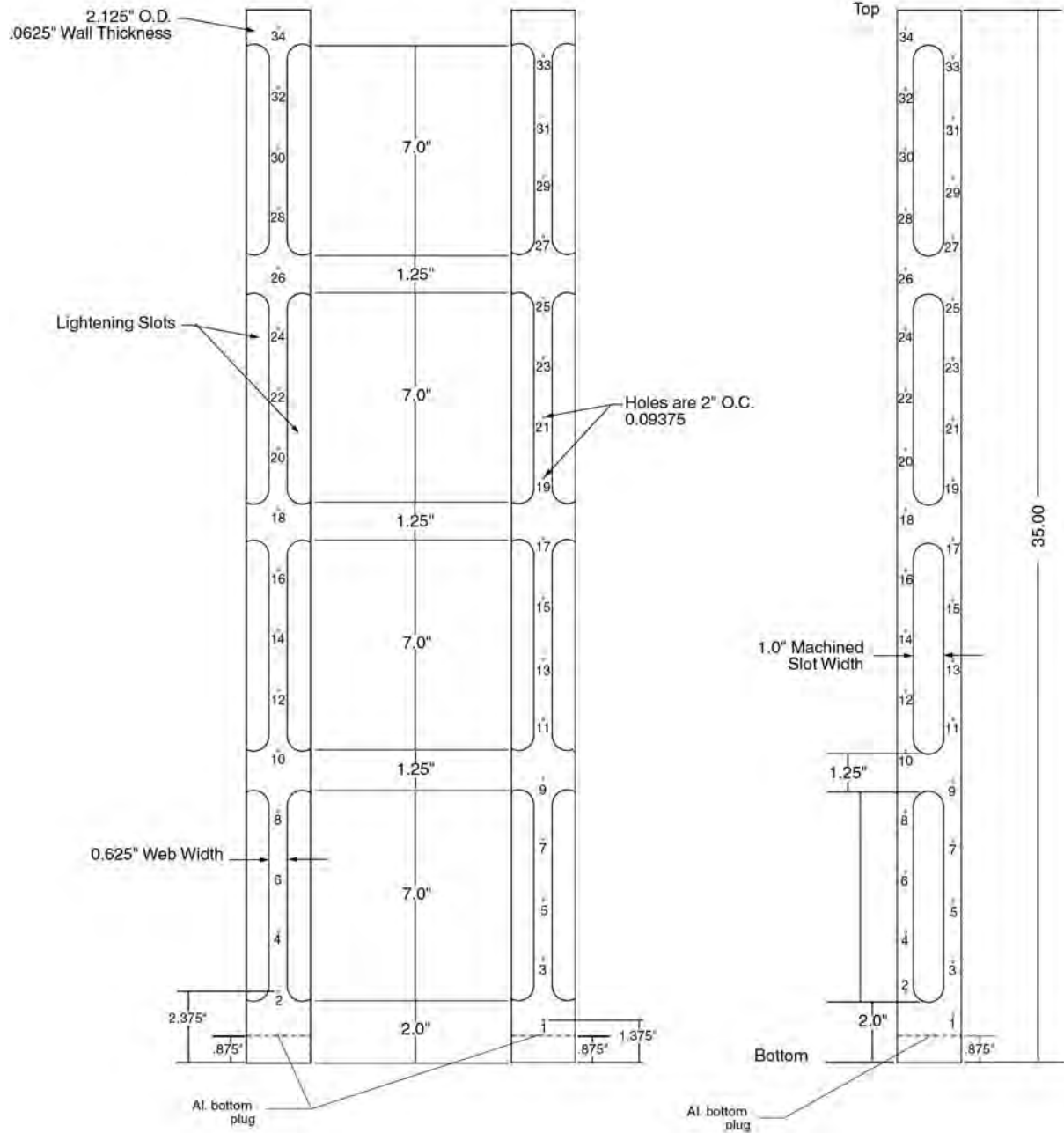

Figure C-4. SWB matrix surrogate PDP standard insert fixture.

## **Appendix D**

# **NDA Performance Demonstration Program Forms**

### PDP SWB Matrix Configuration Form

Facility Name:	SWB Number ____ of ____ in this Cycle	
PDP Sample ID:	Tier Number:	
Matrix Type:	PDP Distribution (Mo/Yr):	Page ____ of ____

Authorized: _____ <small style="margin-left: 100px;">NDA PDP Coordinator</small>	Date: _____
-------------------------------------------------------------------------------------	-------------

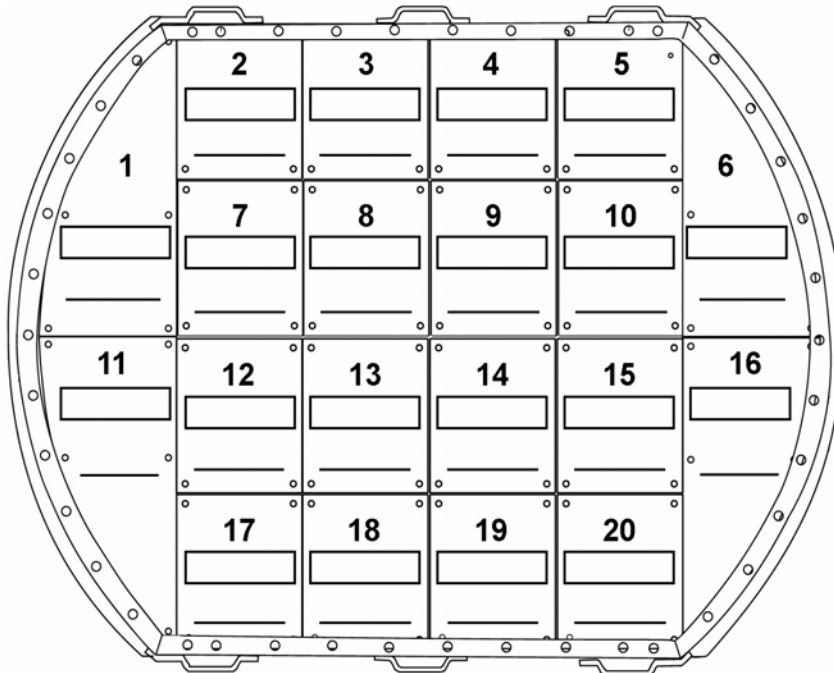

PDP Standards Custodian: _____ <small style="margin-left: 100px;">Signature</small>	Date: _____
----------------------------------------------------------------------------------------	-------------

**PDP Standard Configuration Form for SWB**

Facility Name:	SWB Number _____ of _____ in this Cycle		
PDP Sample ID:	TID Number:		
Matrix Type:	PDP Distribution (Mo/Yr):	Page _____ of _____	

Authorized: \_\_\_\_\_ Date: \_\_\_\_\_  
 NDA PDP Coordinator

Source ID	Primary Nuclear Materials	Activity	Units	SWB Position	Rod Position # Initial

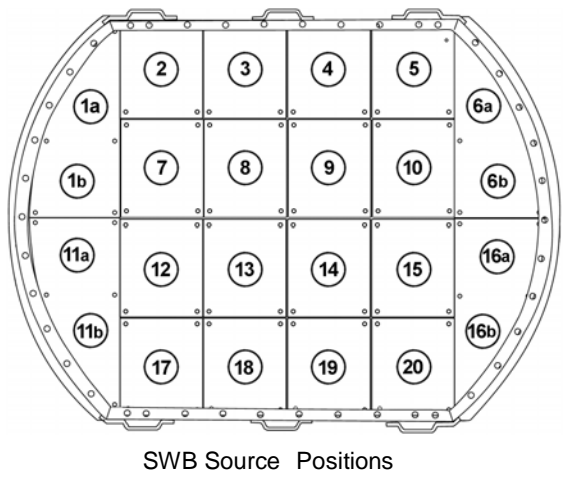
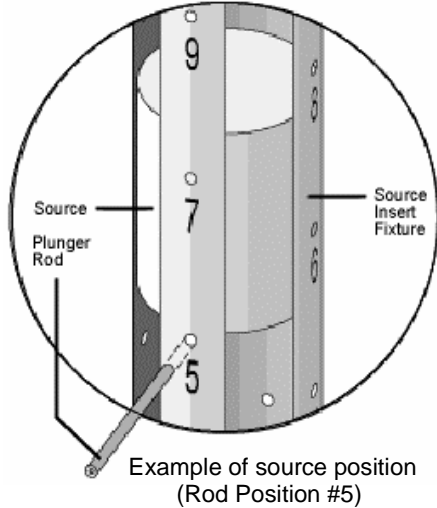

PDP Standards Custodian: \_\_\_\_\_ Signature \_\_\_\_\_ Date: \_\_\_\_\_

### Nondestructive Assay PDP Sample Custody Form

SWB Serial Number: \_\_\_\_\_  
 TID Serial Numbers: \_\_\_\_\_  
 NDA PDP Cycle Number: \_\_\_\_\_

Assay Site: \_\_\_\_\_  
 PDP Sample ID: \_\_\_\_\_

Comments: \_\_\_\_\_  
 \_\_\_\_\_  
 \_\_\_\_\_

#### Sample Preparation

Sample Preparation Date:	_____
SPT Standards Custodian	Date
	Initials
Matrix modules properly placed:	
Standards properly placed:	_____
SWB Matrix Box TIDs properly sealed:	_____
Sample information form attached and sealed:	_____
PDP Standards Configuration Attestant	Date

Relinquished By:	Date/Time	Received by:	Date/Time

Final Disposition By:	Date/Time	Disposition Status

### NDA Box PDP Sample Disassembly Form

SWB Serial Number: \_\_\_\_\_ NDA Box PDP Cycle Number: \_\_\_\_\_  
TID Serial Numbers: \_\_\_\_\_ PDP Sample ID: \_\_\_\_\_

#### Sample Disassembly Record

Sample Disassembly Date: _____					
<u>Condition of Seals and Standards</u>					
Configuration Form attached and sealed:	Yes	<input type="checkbox"/>	No	<input type="checkbox"/>	
Container TID(s) properly sealed:	Yes	<input type="checkbox"/>	No	<input type="checkbox"/>	
Standards properly placed (Cross out if not applicable):					
Source <u>1</u>	Yes	<input type="checkbox"/>	No	<input type="checkbox"/>	Condition: _____
Source <u>2</u>	Yes	<input type="checkbox"/>	No	<input type="checkbox"/>	Condition: _____
Source <u>3</u>	Yes	<input type="checkbox"/>	No	<input type="checkbox"/>	Condition: _____
Source <u>4</u>	Yes	<input type="checkbox"/>	No	<input type="checkbox"/>	Condition: _____
Source <u>5</u>	Yes	<input type="checkbox"/>	No	<input type="checkbox"/>	Condition: _____
Source <u>6</u>	Yes	<input type="checkbox"/>	No	<input type="checkbox"/>	Condition: _____
Source <u>7</u>	Yes	<input type="checkbox"/>	No	<input type="checkbox"/>	Condition: _____
Source <u>8</u>	Yes	<input type="checkbox"/>	No	<input type="checkbox"/>	Condition: _____
Source <u>9</u>	Yes	<input type="checkbox"/>	No	<input type="checkbox"/>	Condition: _____
Source <u>10</u>	Yes	<input type="checkbox"/>	No	<input type="checkbox"/>	Condition: _____
<u>Surrogate matrix modules properly placed:</u>					
Tier 1	Yes	<input type="checkbox"/>	No	<input type="checkbox"/>	Condition: _____
Tier 2	Yes	<input type="checkbox"/>	No	<input type="checkbox"/>	Condition: _____
Tier 3	Yes	<input type="checkbox"/>	No	<input type="checkbox"/>	Condition: _____
Comments:					
_____					
_____					
_____					
_____					
_____			_____		
PDP Standards Configuration Attestant			Date		
_____			_____		
PDP Standards Custodian			Date		

### Nondestructive Assay Performance Demonstration Program Report Form

Laboratory ID: \_\_\_\_\_ Assay Facility: \_\_\_\_\_  
PDP Cycle: \_\_\_\_\_ Supplemental Cycle: \_\_\_\_\_ Replicate: \_\_\_\_\_ of \_\_\_\_\_  
Drum Serial No.: \_\_\_\_\_ Laboratory Sample ID: \_\_\_\_\_

#### Final Result Summary

Parameter	Final Result	Total Uncertainty (One Standard Deviation)
Total <sup>239</sup> Pu fissile gram equivalent (g)		
Total TRU alpha activity (curies)		
Thermal Power (W)		

#### Method Summary

	Identification	Classification	Associated SOP Identification (Including Revision No.)	Count Time (min)	Analysis	
					Date	Time
Method 1						
Method 2						
Method 3						

#### Individual Isotope Data

Isotope	Activity Result	Uncertainty (1sd)		Quantification Method				Method Number (From Summary)
		Count	Total	Direct	Ratio	Scaling Isotope	Ratio Value	
<sup>238</sup> Pu								
<sup>239</sup> Pu								
<sup>240</sup> Pu								
<sup>241</sup> Am								

Comments:

---



---



---

Approval: \_\_\_\_\_  
Signature
Title
Date



## **Appendix E**

### **Statistical Basis of NDA PDP Scoring Criteria**

## Appendix E Statistical Basis of NDA PDP Scoring Criteria

### E.1. DEFINITIONS

#### Limits and Bounds

This discussion describes two types of bounds or limits: (1) those specified as quality assurance objectives (QAOs) that define the *acceptable* precision limits for a nondestructive assay (NDA) measurement system, and (2) the allowable bias range defined by the bounds of the 95% confidence interval. While the terms “limits” and “bounds” can be used interchangeably, to avoid confusion, the term “limits” is used here only in reference to the Performance Demonstration Program (PDP) precision criteria. Similarly, the term “bounds” is used only to describe the endpoints or bounding values of calculated 95% confidence intervals for the percent recovery.

#### Point Estimate

A point estimate is the best single numerical value that is a good indicator of the underlying parameter of interest. Point estimates contrast with confidence bound estimates, which are interval estimates (since they delineate bounds on confidence intervals). For bias, the point estimate is the mean calculated percent recovery (%R), relative to the known value. For precision, the point estimate is the percent standard deviation relative to the known value (%RSD).

### E.2. PERFORMANCE CRITERIA

For a non-interfering matrix, the NDA PDP criteria (Table E-1, column 2) specify acceptable limits for the measured precision of an NDA system based on 15 replicate assay measurements. The NDA PDP criteria are derived from the calibration confirmation criteria for NDA systems in the *Transuranic Waste Acceptance Criteria [WAC] for the Waste Isolation Pilot Plant* (DOE/WIPP-02-3122). The precision criterion, defined as the maximum allowable %RSD for a non-interfering matrix and given in Table A-3.2 of the WAC, is 20.0% for 15 replicate assay measurements. This same precision limit of 20% RSD is given in Table E-1 column 2 for the lowest TRU alpha activity range.

The measured precision, based on 15 replicates, is only an approximation of the true system precision. Implicit in each QAO limit for the measured precision is a corresponding 95% upper confidence endpoint value on the true system precision. These upper limits are stated explicitly in Table E-1. Precision criteria for NDA PDP tests for 6 replicate assay measurements, derived in relation to the upper confidence limits for 15 replicate assay measurements, are given in Table E-1 for non-interfering and interfering matrices.

The accuracy criterion for non-interfering matrix bias, as specified in the WAC, section A.3, *Calibration Confirmation*, is a maximum difference of  $\pm 30\%$  from 100% recovery. This criterion has been adopted for use in the NDA PDP for the non-interfering matrix bias criterion (see Table E-1). The PDP criteria for bias for the interfering matrices, shown in Table E-1, are less restrictive in consideration of the complexities involved with matrix interferences.

Table E-1. NDA PDP performance criteria.

Activity Range in $\alpha$ -curies	Based on WAC %RSD UL <sup>a</sup> (15 Replicates)	Maximum Allowable %RSD (95% CB <sup>b</sup> of UL)	Criteria for Maximum Measured PDP Precision (%RSD) (Six Replicates)		Criteria for Bias (Values for %R <sub>L</sub> and %R <sub>U</sub> for use in Equation 11) (Six Replicates)	
			Non-interfering	Interfering	Non-interfering	Interfering
>0 to 0.02	20	29.2	14.0	16	Lower: 70 Upper: 130	Lower: 40 Upper: 160
>0.02 to 0.2	15	21.9	10.5	12	Lower: 70 Upper: 130	Lower: 40 Upper: 160
>0.2 to 2.0	10	14.6	7.0	12	Lower: 70 Upper: 130	Lower: 40 Upper: 160
>2.0	5	7.3	3.5	6	Lower: 70 Upper: 130	Lower: 40 Upper: 160

a – The 20%RSD value for the low activity range was adopted from the WAC, A.3, *Calibration Confirmation* section. UL values for the remaining increased activity ranges were extrapolated on the basis of the capability of NDA systems of meeting these limits.

b – upper confidence bound for acceptable precision (expressed as %RSD) at the 95% one-sided upper confidence based on 15 replicate measurements

### Precision Criteria for Non-interfering Waste Matrices

The true precision and bias of a measurement system are unknown. Estimates of the values of these parameters are acquired through the analysis of results of the total TRU  $\alpha$ -activity parameter from a set of six replicate assay measurements of the same NDA PDP sample. The more measurements acquired, the better are the precision and bias estimates of the NDA system for a given NDA PDP sample configuration.

The NDA PDP limits for measured precision of a non-interfering type matrix, determined from six replicate samples, are given in Table E-1. The values for six replicate measurements were derived from the upper confidence bounds for 15 replicate measurements. The derivation results in a downward adjustment of the acceptable measured precision values compared to that allowable for 15 replicate measurements, as shown in column 2.

For example, when six replicates are used, a measured value of 18% for the RSD of an assay system in the low activity range, even though less than the 20% allowable using 15 replicates, does not mean the implicit limit of an upper confidence bound of 29.2% has been met. In fact, the 95% one-sided upper confidence bound for this six-replicate example is approximately 38% — considerably higher than the allowable limit. Hence, the allowable measured precision with only six replicates is lower than that for 15 replicates for each  $\alpha$ -activity range.

Since the 95% confidence limit for relative standard deviation depends only on the standard deviation itself, it is possible, with a pre-specified fixed sample size, to determine ahead of time exactly how large the calculated NDA PDP precision-point estimate value can be and still have an associated upper one-sided 95% confidence limit that meets the criteria in Table E-1. The fourth and fifth columns of Table E-1 tabulate these maximum measured relative precision point estimate values using six replicates. The limits in columns 5 and 6 are used to compare the calculated NDA measurement system point estimate for relative standard deviation from six replicate measurements on non-interfering and interfering NDA PDP sample matrices, respectively. (Exactly how the values for interfering matrices were obtained is described below.) Note that comparing the non-interfering NDA measurement system point estimate to the value in column 4 is equivalent to comparing the associated upper one-sided 95% confidence limit to the value in

column 3. That is, an NDA PDP point estimate of the value indicated in column 4 using six replicates will have a 95% upper one-sided confidence limit equal to the value in column 3.

### Calculating Limits for Measured Relative Precision

The limits specified in column 4 for the non-interfering PDP sample relative precision (standard deviation divided by the known value) are derived from confidence interval calculations for the variance (i.e., the square of the standard deviation) of a distribution. The derivation is described below.

#### General Derivation

Let  $\sigma^2$  equal the true variance and let  $1 - \alpha$  equal the desired confidence value. Furthermore, let  $s^2$  equal the sample variance, and  $\chi_{\alpha,n-1}^2$  equal the critical value of a chi-square distribution with  $n - 1$  degrees of freedom above which  $\alpha$  % of the distribution lies; that is, the critical value for the upper  $\alpha$ % tail of the distribution. Then, assuming a normal distribution, a two-sided  $\alpha$  % confidence interval for the true variance is (e.g., Anderson 1987).

$$\frac{(n-1)s^2}{\chi_{\alpha/2,n-1}^2} < \sigma^2 < \frac{(n-1)s^2}{\chi_{1-\alpha/2,n-1}^2} \quad (\text{E-1})$$

Based on this formula for the two-sided interval, the upper one-sided  $(1 - \alpha)$  % confidence limit is

$$\sigma^2 < \frac{(n-1)s^2}{\chi_{1-\alpha,n-1}^2} \quad (\text{E-2})$$

and the corresponding upper limit for the true percent relative standard deviation is calculated as

$$\frac{\sigma}{\mu_0} 100\% < \sqrt{\frac{(n-1) \frac{s^2}{\mu_0^2}}{\chi_{1-\alpha,n-1}^2}} 100\% \quad (\text{E-3})$$

where  $\mu_0$  is the reference (or true) value of the NDA PDP sample.

For the NDA PDP tests,  $n = 6$  and  $\chi_{1-\alpha,n-1}^2 = \chi_{0.05,5}^2 = 1.145$  in Equation E-3. Substituting these values and the known value of the NDA PDP sample for  $\mu_0$  in this formula gives an approximate upper one-sided 95% confidence limit for the percent relative standard deviation for six replicates. If desired, this upper confidence limit can be directly compared to the numbers in column 3 of Table E-1 to determine if an assay system has met the relative precision criteria.

The numbers in column 4 of Table E-1 are derived by comparing the right portion of Equation E-3 to the appropriate number in column 3 of Table E-1 and solving for  $s/\mu_0$ . As an example, for the low activity range this calculation begins with the QAO required inequality

$$\sqrt{\frac{(n-1) \frac{s^2}{\mu_0^2}}{\chi_{1-\alpha, n-1}^2}} 100\% < 29.2\% \quad (\text{E-4})$$

Solving for  $s/\mu_0$  gives

$$\frac{s}{\mu_0} 100\% < \sqrt{\frac{(0.292)^2 \chi_{1-\alpha, n-1}^2}{n-1}} 100\% \quad (\text{E-5})$$

which, for six samples and 95% confidence as specified in the PDP, gives

$$\frac{s}{\mu_0} 100\% < \sqrt{\frac{(0.292)^2 (1.145)}{5}} 100\% = 14\% \quad (\text{E-6})$$

Again, substituting the reference (or true) value of the NDA PDP sample for  $\mu_0$  indicates that a calculated relative standard deviation of 14% or less meets the criterion for relative precision in the low activity range. Since the chi-square value and  $n$  are the same for all activity levels, the column 4 values for the other activity levels are obtained simply by substituting the appropriate value in place of 0.292 in Equation E-6.

## Precision Criteria for Interfering Waste Matrices

The WAC limits (section A.3, *Calibration Confirmation*) are specified for a “non-interfering matrix”; in other words, a waste matrix that does not have attributes that manifest themselves in the NDA measurement system as significant complicating error elements. To determine rational precision scoring criteria for the interfering type waste form, it was necessary to establish some relationship to program objectives that can be used as a basis for the NDA PDP criteria for the interfering matrix drums. There are certain program-defined limits for which assay systems are used to ensure compliance. In particular, there are the 200 fissile gram equivalent (FGE) material limits for 55-gallon containers and the TRU waste  $\alpha$ -activity definition used to discriminate TRU waste from low-level waste (LLW). At the high end, the precision of the assay system should be reasonable for waste containers approaching the 200 FGE limit to ensure that an excessive number of drums do not exceed the limit at the 95% confidence level. Similarly, the waste assay system should be sufficiently precise for containers of low TRU mass loading (i.e., in the vicinity of the 100 nCi/gram  $\alpha$ -activity criterion) to ensure that an unacceptable number of containers of TRU waste are not classified as LLW.

As a convenient base for determining precision criteria for interfering type waste matrix drums, the non-interfering compliance points in Table E-1 are used. For the low activity range, the nominal compliance point for meeting the WAC precision and bias criteria is 100 mg of weapons-grade plutonium (WG Pu). An acceptable assay system should be capable of detecting and quantifying TRU waste in 55-gallon waste containers at a level of 35 mg WG Pu, approximately 75 nCi/g waste at 100 pounds of waste. When assaying a container at the compliance point of 100 mg WG Pu, we would like to be sure at the 95% confidence level that the assay system will not return a value less than 35 mg WG Pu. This provides reasonable protection against classifying TRU waste as LLW. Based on this rationale, two standard deviations would correspond to 65 mg (100 mg–35 mg). One relative standard deviation would therefore be 32.5mg/100 mg or 0.325. By substituting 0.325 in place of 0.292 in Equation E-6, we obtain a value of

0.155 (rounded up to 0.16) for the measured precision criterion for six replicate determinations of an interfering matrix drum in the low activity range.

Using similar reasoning, a precision criterion can be assigned to the high-mass region. In this case, the nominal compliance point used is 160 g WG Pu. When assaying a container at the compliance point of 160 g WG Pu, we would like to be sure at the 95% confidence level that the assay system will not return a value greater than 200 g WG Pu. This provides reasonable protection against mistakenly classifying a TRU waste drum as not shippable when in fact it does not exceed the limit. Based on this rationale, two standard deviations would correspond to 40 g (200 g–160 g). One relative standard deviation would therefore be 20 g/160 g or 0.125. By substituting 0.125 in place of 0.292 in Equation E-6, we obtain a value of 0.0598 (rounded up to 0.06) for the measured precision criteria for six replicate determinations of an interfering matrix drum in the high activity range.

No compelling programmatic objectives argue for specific precision limits for the low-middle and high-middle ranges, although some thermal limits will fall into these ranges for some waste forms. Therefore, it was felt that arbitrary limits based on consistency and continuity in the use of the assay systems would be adequate for these ranges. The precision criteria for the low-middle and high-middle ranges were set at 0.12 for the RSD of six replicate determinations.

### E.3 CALCULATING CONFIDENCE BOUNDS FOR BIAS

The comparison of an assay system's performance to the bias requirements for the non-interfering and interfering NDA PDP samples requires calculation of the 95% two-sided confidence bounds for the true value, using the replicate measurement data set. Based on a *t*-distribution, the  $(1 - \alpha)$ % two-sided confidence bounds for the true assay system mean are (assuming a normal distribution):

$$\bar{x} - t_{1-\alpha/2, n-1} \frac{s}{\sqrt{n}} \leq \mu_0 \leq \bar{x} + t_{1-\alpha/2, n-1} \frac{s}{\sqrt{n}} \quad (\text{E-7})$$

In terms of percent recovery, the bounds are

$$\frac{\bar{x} - t_{1-\alpha/2, n-1} \frac{s}{\sqrt{n}}}{\mu_0} \times 100\% < 100\% < \frac{\bar{x} + t_{1-\alpha/2, n-1} \frac{s}{\sqrt{n}}}{\mu_0} \times 100\% , \quad (\text{E-8})$$

where  $\mu_0$  is the known (or true) value. The lower and upper bounds, calculated per Equation E-8, must be greater than or equal to %R<sub>L</sub> and less than or equal to %R<sub>U</sub>, respectively, where %R<sub>L</sub> and %R<sub>U</sub> are the appropriate lower and upper range-specific QAOs from Table E-1. Equivalently, bounds for the point estimate, total TRU  $\alpha$ -activity percent recovery, can be obtained by solving the required inequalities for percent recovery. The required inequalities are:

$$\frac{\bar{x} - t_{1-\alpha/2, n-1} \frac{s}{\sqrt{n}}}{\mu_0} 100\% > \%R_L \quad \text{and} \quad \frac{\bar{x} + t_{1-\alpha/2, n-1} \frac{s}{\sqrt{n}}}{\mu_0} 100\% \leq \%R_U \quad (\text{E-9})$$

which, on solving for percent recovery, gives

$$\%R_L + \frac{t_{1-\alpha/2, n-1} \frac{s}{\sqrt{n}}}{\mu_0} 100\% \leq \frac{\bar{x}}{\mu_0} 100\% \leq \%R_U - \frac{t_{1-\alpha/2, n-1} \frac{s}{\sqrt{n}}}{\mu_0} 100\% \quad (E-10)$$

With six samples,  $n = 6$ , and the corresponding  $t$  value (for 95% two-sided confidence bounds) is 2.571. Thus, the equation simplifies to:

$$\%R_L + \frac{1.049s}{\mu_0} 100\% < \frac{\bar{x}}{\mu_0} 100\% < \%R_U - \frac{1.049s}{\mu_0} 100\% \quad (E-11)$$

#### E.4 REFERENCES

Anderson, R. L. 1987, *Practical Statistics for Analytical Chemists*, New York, Van Nostrand Reinhold.

DOE/WIPP-02-3122, *Transuranic Waste Acceptance Criteria for the Waste Isolation Pilot Plant*, current revision, U.S. Department of Energy Waste Isolation Pilot Plant, Carlsbad, New Mexico.